

TOSHIBA

OWNER'S MANUAL

900 MHz DIGITAL

**SPREAD SPECTRUM TRANSMISSION
CORDLESS TELEPHONE WITH DIGITAL ANSWERING SYSTEM**

SX-2908BK



The **FIRST** thing to do after unpacking your new cordless telephone is:

CHARGE THE BATTERY !

Please read and follow the few instructions on

PAGE 1

BEFORE YOU DO ANYTHING ELSE.



GETTING STARTED: DO THIS FIRST!

FIRST, After unpacking your new cordless phone:

CHARGE THE HANDSET BATTERY!

- **Set your new phone in an out-of-the-way place near a power outlet but where it will not be disturbed. Do not connect it to the telephone line.**
- Plug the AC adaptor into the wall power outlet.
- Plug the AC adaptor cord into the power jack on the base unit. The "POWER" LED should light. If not, see "**TROUBLESHOOTING**," page 43.
- Take the covers off the handset and base unit battery compartments, place one battery pack in each compartment, being sure that the metal terminals on the batteries are in contact with the connectors in their respective compartments, and replace the cover on each compartment.
- Place the handset into the base unit's charging cradle. The "CHARGE" LED should light.
- The battery charging period has now started. From now until the 12 hour period is complete, do not let anything cause the handset to be removed from electrical contact with the base unit's charging pins or power to be removed from the base unit.

SECOND, after completing the 12 hour charge period, connect the base unit to the telephone line modular jack, using the six foot long modular line cord. If the unit is to be wall mounted, use the six inch cord.

Now, set the Tone-Pulse switch for your type of service according to the instructions on Page 22 and your telephone is ready for normal use. Information on the use of other features follows on page 23.

TABLE OF CONTENTS

IMPORTANT SAFETY INSTRUCTIONS	4
INTRODUCTION	7
Features	7
Parts identification	8
INSTALLATION	10
Installing the handset battery pack	10
Installing the base unit battery pack	11
Setting up the base unit	12
AC adaptor information	13
Wall mounting	13
Charging the battery packs	15
LOCATION OF CONTROLS	16
POWER FAILURE PROTECTION	21
BASICS	22
Tone/Pulse selection	22
Making a call	23
Answering a call	24
Putting a call on mute	24
Adjusting the ringer volume	25
Adjusting the volume level of the handset	26
Last number redial	26
Call waiting	27
Banking and telephone services	27
Paging the handset	28
MEMORY DIAL	29
Storing numbers	29
Dialing a stored number	30
Erasing a stored number	30
Using the memory dialing or PBX	30
USING THE ANSWERING MACHINE	31
Setting the clock	31
Recording the outgoing message (OGM)	32
Turning the answering machine on & off	33

TABLE OF CONTENTS

To change the outgoing message (OGM)	33
Setting the number of rings	34
Setting maximum recording time for incoming messages	34
Setting Announce Only	34
Playing recorded messages	35
Deleting recorded messages	36
Screening incoming calls	36
Leaving a memo message	37
Recording a phone conversation (2WAY REC)	38
REMOTE OPERATION	39
Setting the PIN number	39
Calling in from a remote location	40
Table of commands	41
ADDITION	42
Carrying the handset in the belt clip	42
TROUBLESHOOTING	43
SPECIFICATIONS	46
WARRANTY/SERVICE	48
REMOTE OPERATION CARDS	51

IMPORTANT SAFETY INSTRUCTIONS

When using your telephone equipment, basic safety precautions should always be followed to reduce the risk of fire, electric shock and injury.

- 1 Read and understand all instructions.
- 2 Follow all warnings and instructions marked on the product.
- 3 Unplug this product from the wall outlet before cleaning. Do not use liquid cleaners or aerosol cleaners. Use a dry cloth for cleaning.
- 4 Do not use this product near water, for example, near a bath tub, wash bowl, kitchen sink, or laundry tub, in a wet basement, or near a swimming pool.
- 5 Do not place this product on an unstable cart, stand, or table. The telephone may fall, causing serious damage to the telephone.
- 6 Slots and openings in the cabinet and the back or bottom are provided for ventilation, to protect the phone from overheating. These openings must not be blocked or covered. The openings should never be blocked by placing the product on a bed, sofa, rug, or other similar surface. This product should never be placed near or over a radiator or heat register. This product should not be placed in a built-in installation unless proper ventilation is provided.
- 7 Do not allow anything to rest on the power cord. Do not locate this product where the cord can be stepped on or tripped over.
- 8 Do not overload wall outlets and extension cords as this can result in the risk of fire or electric shock.
- 9 Never push objects of any kind into this product through cabinet slots as they may touch dangerous voltage points or short out parts that could result in a risk of fire or electric shock. Never spill liquid of any kind on the product.
- 10 Do not disassemble this product. Opening or removing covers puts you at risk of electrical shock, and incorrect reassembly can cause shocks, sparks or other damage during subsequent use.
- 11 Take this product to a qualified service technician under any of the following conditions:
 - A. When the power supply cord is damaged or frayed.
 - B. If liquid has been spilled into the product.
 - C. If the product has been exposed to rain or water.
 - D. If the product does not operate normally according to the operating instructions. Adjust only those controls covered by this manual. Improper adjustment of other controls may result in serious damage to the unit or your home.
 - E. If the product has been dropped or the cabinet has been damaged.
 - F. If the product exhibits a distinct change in performance.
- 12 Do not use the telephone to report a gas leak in the vicinity of a gas leak.

IMPORTANT SAFETY INSTRUCTIONS

The RBRC™ Seal

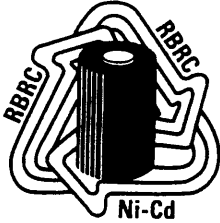

The RBRC™ Seal on the (easily removable) nickel-cadmium battery (contained in our product) indicates that Toshiba America Consumer Products, Inc. (TACP) is voluntarily participating in an industry program to collect and recycle these batteries at the end of their useful lives, when taken out of service within the United States. The RBRC™ program provides a convenient alternative to placing used nickel-cadmium batteries into the trash or municipal waste, which is illegal in some areas.

TACP's payments to RBRC™ make it easy for you to drop off the spent battery at local retailers of replacement nickel-cadmium batteries, or at authorized TACP product service centers. You may also contact your local recycling center for information on where to return the spent battery. Please call 1-800-8-BATTERY for information on Ni-Cd battery recycling in your area. TACP's involvement in this program is part of its commitment to protecting our environment and conserving natural resources.

RBRC™ is a trademark of Rechargeable Battery Recycling Corporation.

IMPORTANT SAFETY INSTRUCTIONS

CAUTION: TO REDUCE THE RISK OF FIRE OR INJURY TO PERSONS BY BATTERY, READ AND FOLLOW THESE INSTRUCTIONS.

BATTERIES

- 1 Use only the appropriate type and size battery pack specified in the instruction manual provided for this product.
- 2 Do not dispose of the battery pack in a fire. The cell may explode. Check with State and local codes for possible special disposal instructions.
- 3 Do not open or mutilate the battery pack. Released electrolytes are corrosive and may cause damage to the eyes or skin. It may be toxic if swallowed.
- 4 Exercise care in handling the batteries. Contact with conductive materials such as rings, bracelets and keys may cause the battery to short out, resulting in overheating which could burn.
- 5 Charge the battery pack provided with or identified for use with this product only in accordance with the instructions and limitations specified in the instruction manual provided for this product.
- 6 Observe proper polarity orientation between the battery pack and battery charger.

ATTENTION: THE PRODUCT THAT YOU HAVE PURCHASED CONTAINS A RECHARGEABLE BATTERY. UNDER VARIOUS STATE AND LOCAL LAWS, IT MAY BE ILLEGAL TO DISPOSE OF THIS BATTERY INTO THE MUNICIPAL WASTE STREAM. PLEASE CHECK WITH YOUR LOCAL GOVERNMENT FOR DETAILS IN YOUR AREA REGARDING RECYCLING OPTIONS OR PROPER DISPOSAL.

SAVE THESE INSTRUCTIONS

TO HELP PROTECT THE ENVIRONMENT, THIS PRODUCT MAY CONTAIN RECYCLED OR RECONDITIONED PARTS AND MATERIALS.

INTRODUCTION

FEATURES

Toshiba America Consumer Products takes pride in presenting the SX-2908BK cordless telephone and digital message system. An all digital answering device provides many new conveniences not available on tape machines, such as repeat, skip and individual message delete.

Cordless Phone Features

- 900 MHz Spread Spectrum
- 20 Channel Auto-scanning
- 20 Number Speed Dial
- Handset Locator/Page
- 7 days Standby Battery Life
- Low Battery Indicator
- Wall Mountable
- Hearing Aid Compatible

Answering Machine Features

- 15 Minutes Record Time
- Flash Memory IC
- Time & Day Stamp
- Base Call Screening
- Remote Access
- Play/Skip/Repeat/Delete
- Conversation Record/Memo
- Prerecorded OGM Option

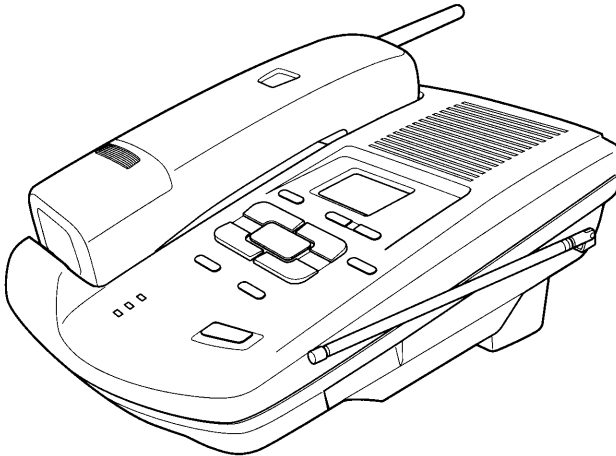

INTRODUCTION

PARTS IDENTIFICATION

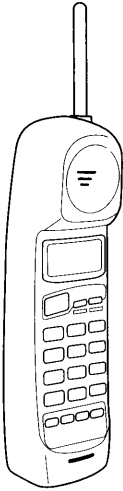

Handset

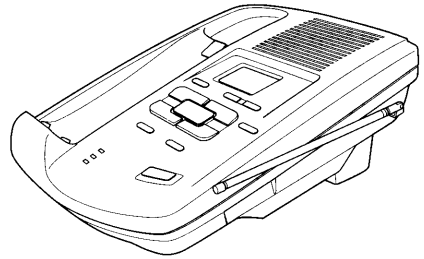

Base Unit

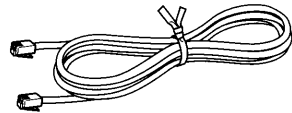

**6' Modular Line Cord
Part #.RC001861**

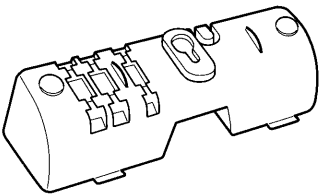

**Desk Top/Wall Mount Bracket
Part #.RC005679**

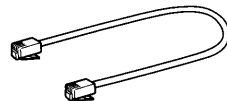

**6" Modular Line Cord
Part #.RC001872**

INTRODUCTION

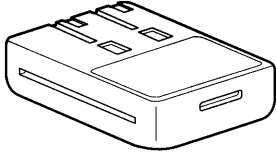

Rechargeable Battery Pack (2)
Toshiba TRB-8258
Part #.RC005634

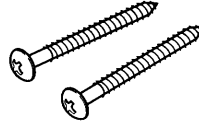

Screws (2)
(for the wall mount)
Part #.RC000936

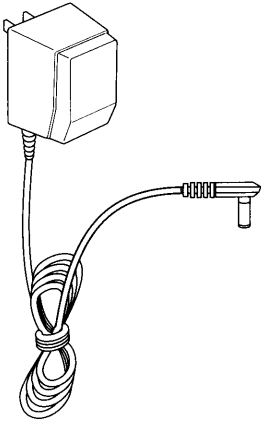

AC Adaptor TAC-8908BK
Part #.RC008834

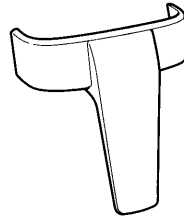

Belt Clip
Part #.RC008880



Owner's manual
Part #.RC008882

SPEED DIAL INDEX	
01	02
03	04
05	06
07	08
09	10
11	12
13	14
15	16
17	18
19	20

Directory Card
Part #.RC008881

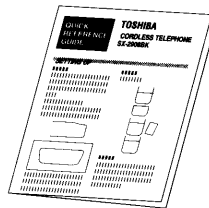

Quick Reference Guide
Part #.RC008883

INSTALLATION

INSTALLING THE HANDSET BATTERY PACK

NOTE: Be sure to charge the handset 12-16 hours before use.

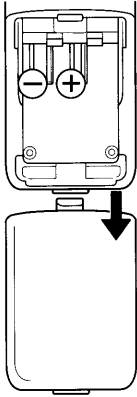

- 1** Remove the battery compartment cover on the back of the handset by sliding it down.

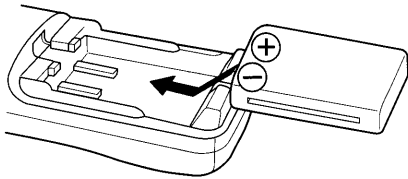

- 2** Place the battery pack in the battery compartment.

NOTE: Make sure to place the battery in the proper direction for correct polarity.

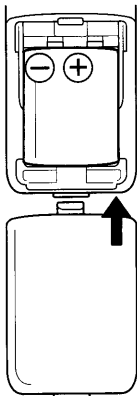

- 3** Put the battery compartment cover back in its original place by sliding it up until it clicks shut.

INSTALLATION

INSTALLING THE BASE UNIT BATTERY PACK

NOTE: Be sure to charge the base unit battery for 24 hours before use.

- 1** Place the battery pack in the battery compartment.

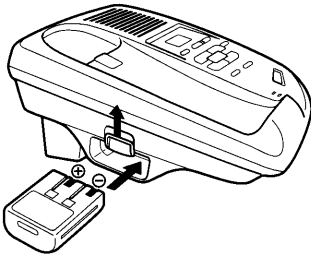
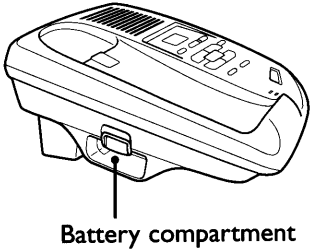

NOTES:

- Make sure to place the battery in the proper direction for correct polarity.
- When the battery power of the handset becomes low, replace it with the battery of the base unit.

INSTALLATION

SETTING UP THE BASE UNIT

For use on a desk or counter top follow the instructions below. For Wall Mounting directions, proceed to the next page.

MOUNTING THE BRACKET FOR DESKTOP INSTALLATION:

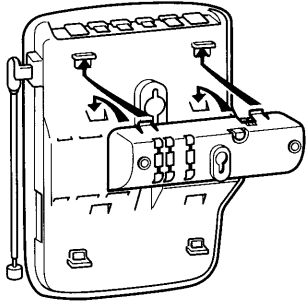

Snap the bracket (with the cutout facing down) into the 4 holders on the upper portion of the base unit's underside. Turn the base unit over and place it on a desk. See that the bracket is firmly mounted on the base unit.

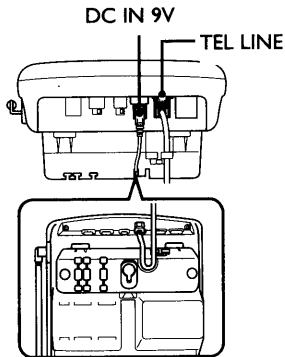

- 1** Make sure that your telephone jack is located near an electrical outlet. To ensure constant functioning, the outlet should not be controlled by a light switch. If the outlet is farther away, you may need an extension cord.
- 2** Plug one end of the telephone line cord into the back of the base in the slot labelled TEL LINE, and plug the other end into the telephone jack.
- 3** Insert the tip of the AC adaptor into the slot labelled DC IN 9V on the back of the base, and plug the other end into the electrical outlet.

NOTE:

Use only the supplied AC adaptor, or one matching its specifications exactly, with this product. Incorrect voltage may damage the unit or cause it to function improperly.

INSTALLATION

AC ADAPTOR INFORMATION

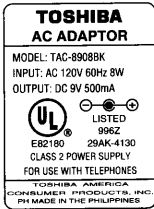

Use only the supplied AC adaptor, or one matching its specifications exactly, with this product. Incorrect voltage may damage the unit or cause it to function improperly.

WALL MOUNTING

This wall mounting system is designed to work with a standard wall jack plate with two protruding nail-like heads on either side of the jack opening. They are available at most phone or electronics retailers.

To mount the base on the wall using a baseboard jack, cut out the template on page 46 to position screws.

MOUNTING THE BRACKET FOR WALL INSTALLATION:

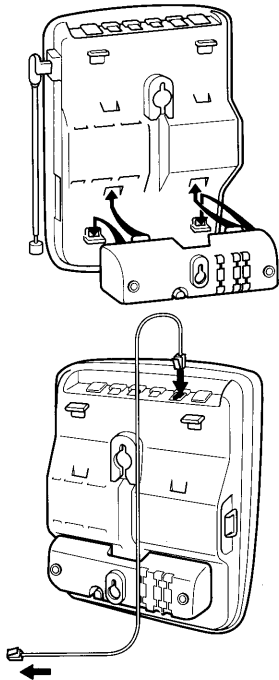

Fix the bracket vertically on the wall. Snap the bracket (with the cutout facing up) into the 4 holders on the lower portion of the base unit's underside.

- 1** Make sure that your telephone jack is located near an electrical outlet. To ensure constant functioning, the outlet should not be controlled by a light switch. If the outlet is farther away, you may need an extension cord.
- 2** Plug one end of the telephone line cord into the back of the base unit in the TEL LINE jack, and plug the other end into the telephone line outlet . Position the telephone line cord through the holder channel on the underside of the base unit.

INSTALLATION

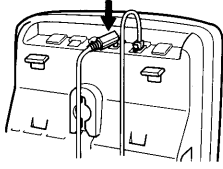

3 Insert the tip of the AC adaptor into the DC IN 9V jack on the back of the base unit.

4 Position the AC adaptor cord through the holder channel on the underside of the base unit.

5 Position the base over the wall plate “screws”. Plug the line cord into the jack. Press the unit toward the wall and then down to secure it properly.

6 Remove the switch hook tab and flip it over as shown, then plug the AC adaptor into the electrical outlet.

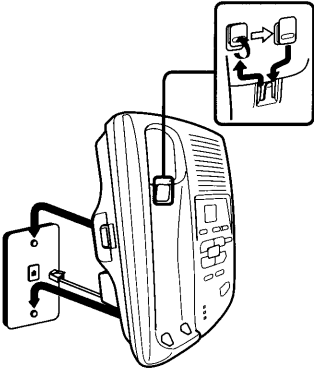

NOTE: Use only the supplied AC adaptor, or one matching its specifications exactly, with this product. Incorrect voltage may damage the unit or cause it to function improperly. See page 13 for information.

INSTALLATION

CHARGING THE BATTERY PACKS

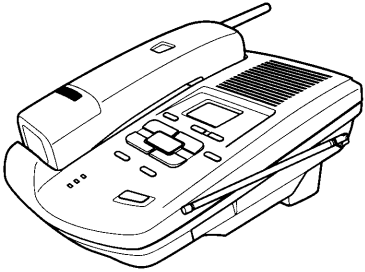

- 1** After installing the battery packs and setting up the base unit, place the handset on the base unit.

You can place the handset in its cradle with the dial pad facing up or down to charge the battery packs.

- 2** The CHARGE LED lights to show that the handset is charging.

If the LED does not light, make sure the AC adaptor is plugged in securely and that the electrical outlet is working and not controlled by a light switch.

If the LED still does not light, verify that the charging contacts are clean and untarnished. Clean the contacts occasionally with a dry cloth.

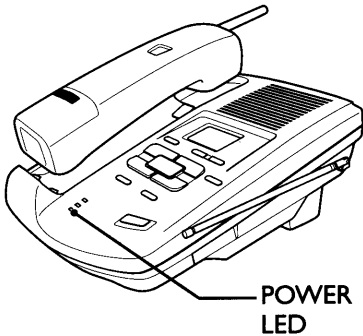
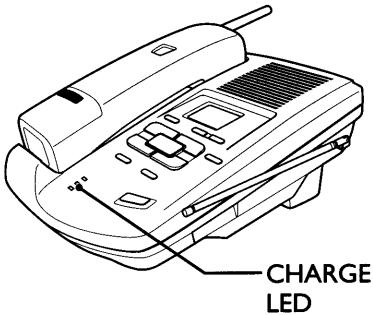

NOTE: When the battery in the base unit is charged, the POWER LED lights in orange. When the battery is not charged, the LED lights in red.

LOCATION OF CONTROLS

HANDSET

TALK/BATT LOW LED (Red)

- Standby status: OFF
- Lights ON during a phone conversation using the handset.
- Blinks during storing memory numbers, and during the low battery status.

TALK button

Press to make a call, receive a call or hang up after a call (See pages 23, 24). (For Call Waiting service, press the FLASH button).

PHONE button

If you have Rotary/Pulse service, press this button and you can have temporary tones for use with bank and other telephone services (See page 27).

MEM (Memory) button

Press to make a call using a preset speed dial number. Also used for programming speed dial numbers into the phone (See pages 29, 30).

MUTE button

Press to mute your voice (See page 24).

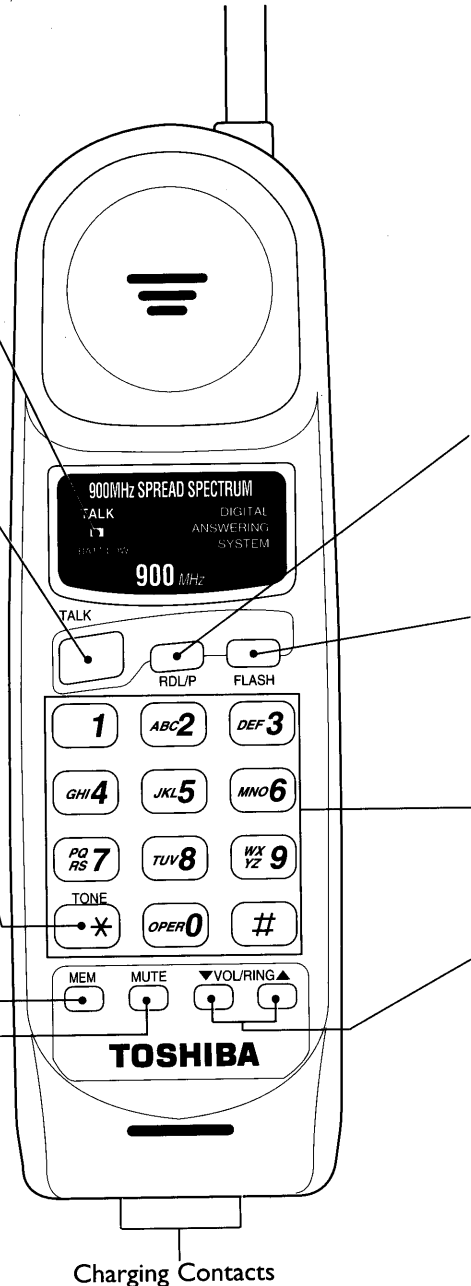

LOCATION OF CONTROLS

SPEED DIAL INDEX

Affix the Speed Dial Index card supplied with your telephone set here. You can write down the numbers preset in the speed dial memory on this card.

RDL/P (Redial/Pause) button

Used to redial the last number dialed (See page 26).

Used to insert a pause in speed dial numbers (See pages 29, 30).

FLASH button

Used in conjunction with telephone company services, such as Call Waiting (See page 27).

Press to adjust the ringer tone of the handset (See page 25).

Dialpad

Used to dial phone numbers.

VOL/RING button

Press to adjust the volume level of the handset (See page 26).

Press to adjust the ringer volume of the handset (See page 25).

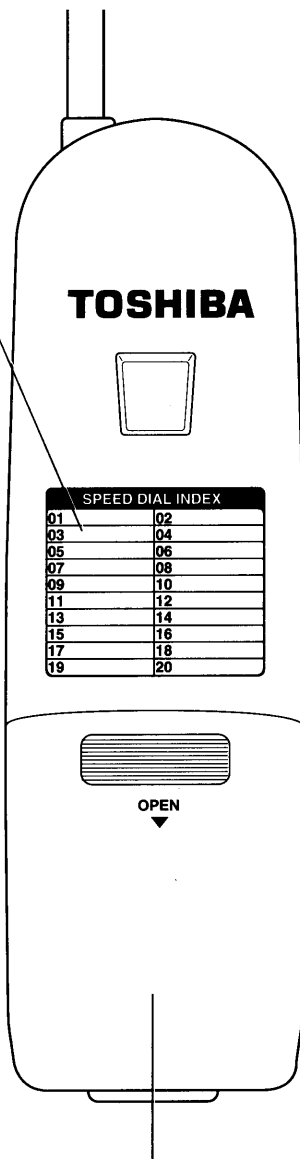

Battery Compartment – Install the rechargeable battery pack here. Charge for at least 12 hours whenever installing or replacing the battery (See page 10).

LOCATION OF CONTROLS

BASE UNIT

FRONT VIEW:

OGM button

Used to record a personalized outgoing message (See page 32).

ANSWER button

Press to turn the answering machine on and off (See page 33).

REPEAT button

Press during playback to play the incoming message again. Press and hold the button to repeat the messages (See page 35). This button will also function as ▼ to select a PIN number (See page 39), or to set the clock (See page 31).

PIN button

Sets the PIN (See page 39).

IN USE LED

Lights when the line is engaged.

CHARGE LED

Lights when the handset is being charged.

POWER LED

Lights when the SX-2908BK is turned on (See page 21).

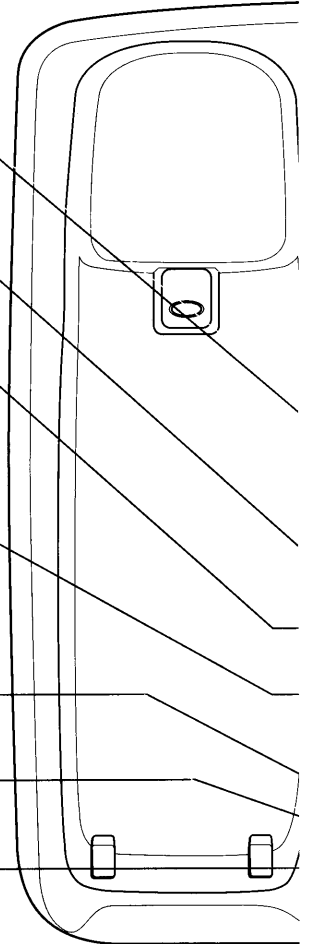

LOCATION OF CONTROLS

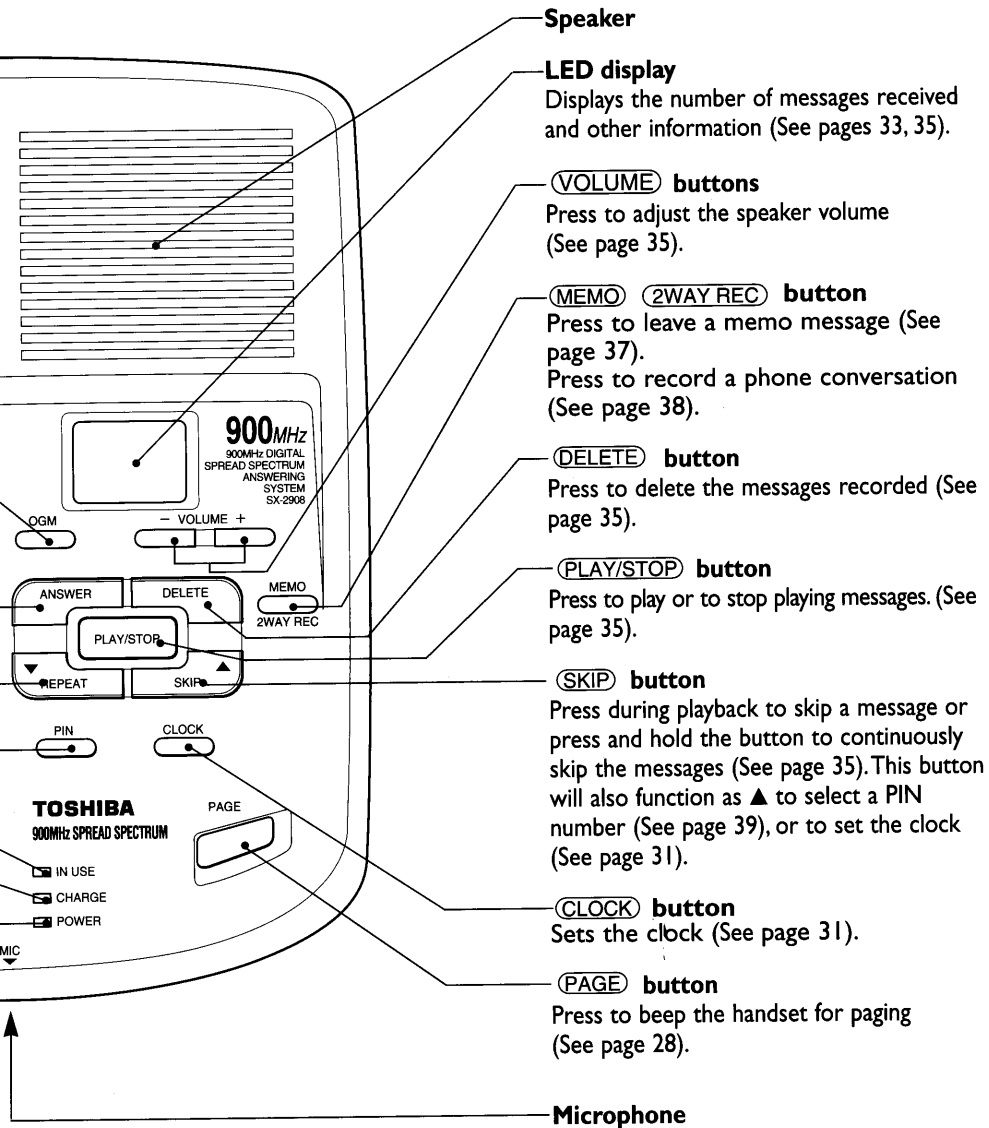

LOCATION OF CONTROLS

REAR VIEW:

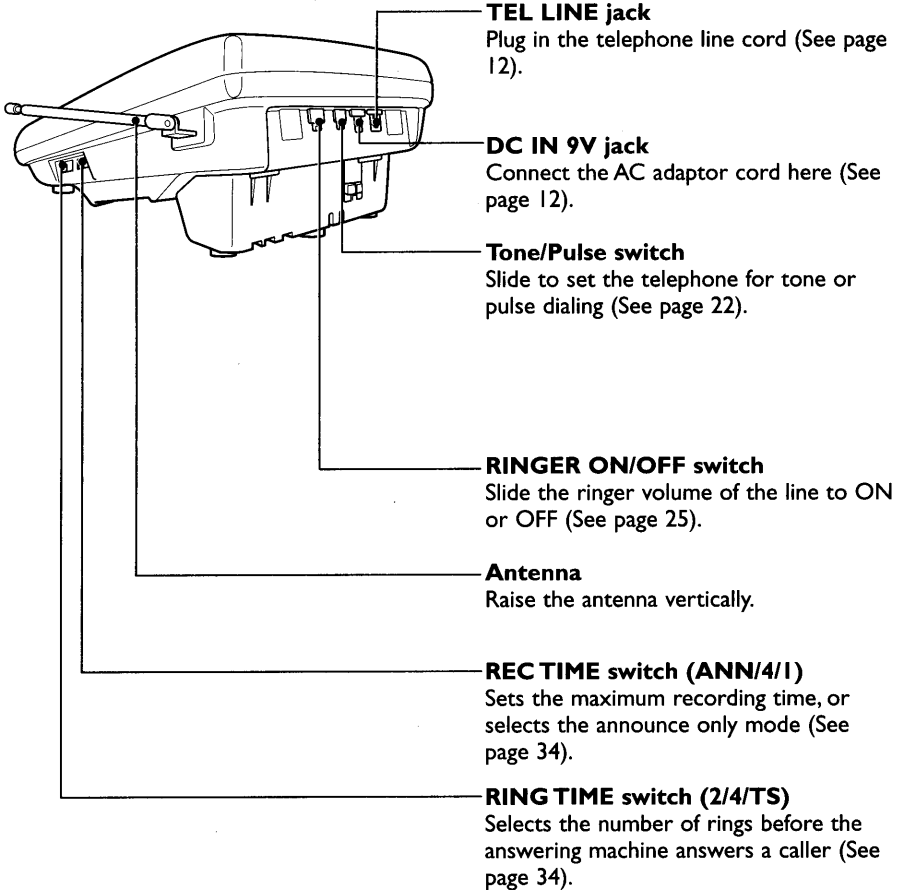

POWER FAILURE PROTECTION

While the battery is installed in the base unit, normal operation on the handset can be maintained for a certain period even if a power failure occurs (only when the battery is charged). The POWER LED lights in different colors depending on the operation status.

- AC adaptor operation with the base battery: Lights in orange.
- AC adaptor operation without base battery: Lights in red.
- Base battery operation during a power failure: Lights in green.

NOTE:

The answering machine does not operate during base battery operation.

BASICS

TONE/PULSE SELECTION

Set the Tone-Pulse switch for the type of service you have, tone or pulse. If you are not sure which type of service you have:

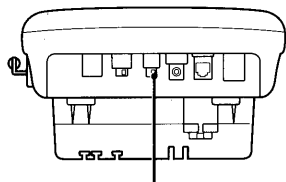

TONE-PULSE switch

- 1** Set the TONE-PULSE switch to TONE.
- 2** Press the **TALK** button on the handset and listen for a dial tone.
- 3** Press any number other than 0. If the dial tone stops, you have Tone service. If the dial tone continues, you have Pulse service.
- 4** If you have Pulse service, set the TONE-PULSE switch to PULSE.

See also "BANKING AND TELEPHONE SERVICES" page 27.

MAKING A CALL

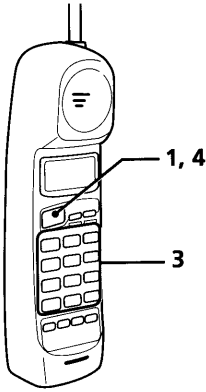

- 1** Press the **TALK** button to connect.
- 2** Listen for the dial tone.
- 3** Key in the phone number you are calling.
- 4** To hang up, press the **TALK** button again or place the handset on the cradle of the base unit. The TALK/BATT LOW LED turns off and the handset is put in standby.

NOTES:

- If the handset battery becomes weak during conversation, warning beeps will sound every 4 seconds. Finish the call as soon as possible and return the handset to the base unit for recharging.
- If the handset is too far away from the base unit, the line may not disconnect even if you press the **TALK** button. In such a case, you will hear a beep sound indicating an error. To disconnect the line, bring the handset near the base unit and press the **TALK** button again, or return the handset to the base unit.
- If a power interruption occurs, press the **TALK** button. The handset returns to standby mode.

BASICS

ANSWERING A CALL

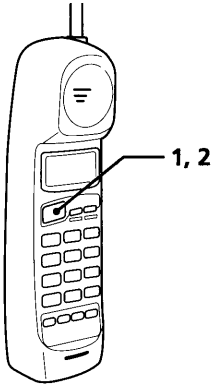

- 1 If you simply pick up the handset when it is in its cradle on the base unit, it will connect automatically.

If the handset is located away from the base unit, press the **TALK** button to connect.

The TALK/BATT LOW LED will light and you can talk to the caller.

- 2 To hang up, press the **TALK** button or place the handset in its cradle on the base unit.

The TALK/BATT LOW LED turns off and the handset is put in standby status.

NOTE:

You can answer a call by pressing any key (Any-key answer function).

PUTTING A CALL ON MUTE

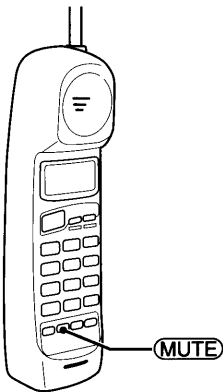

- 1 Press the **MUTE** button during conversation.

The TALK/BATT LOW LED will blink and you can hear the other party but the other party cannot hear your voice.

- 2 To resume conversation, press the **MUTE** button again.

ADJUSTING THE RINGER VOLUME

BASE UNIT:

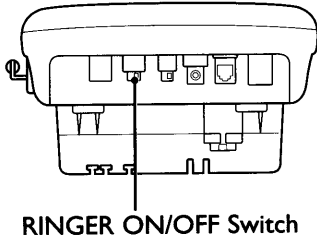

You can turn the ringer sound on or off by sliding the RINGER ON/OFF switch on the base unit.

To turn the ringer on:

Slide the switch to ON position.

To turn the ringer off:

Slide the switch to OFF position.

NOTE:

When the handset is placed in the base unit, only the ringer on the handset will sound.

HANDSET:



Set the ringer volume or sound of the handset during standby mode.

To adjust the ringer volume:

Press the **▼VOL/RING▲** button to set the ringer volume high or low.

To adjust the ringer tone:

Press the **FLASH** button and **① ~ ④** button to select the ringer tone from 4 choices.

- ① : Ringer tone A
- ② : Ringer tone B
- ③ : Ringer tone C
- ④ : Ringer tone D

After each setting the ringer sounds about 1 second.

BASICS

ADJUSTING THE VOLUME LEVEL OF THE HANDSET



Adjusting the volume of incoming calls through the handset during conversation. Four handset volume levels are available. Press the **▼VOL/RING** button to reduce the volume by one level. Press the **▼VOL/RING▲** button to increase it by one level.

NOTE:

*If you press the **▼VOL/RING▲** button when the volume is maximum, a warning beep is emitted and the level does not change. The same applies if you press the **▼VOL/RING** button when the volume level is minimum.*

LAST NUMBER REDIAL

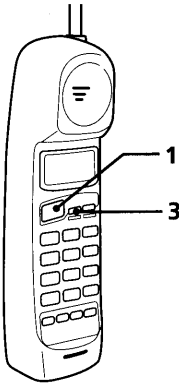

To redial the last number that you called.

- 1** Press the **TALK** button.
- 2** Wait for dialtone.
- 3** Press the **RD/LP** button.

NOTE:

You cannot redial numbers with more than 32 digits.

CALL WAITING

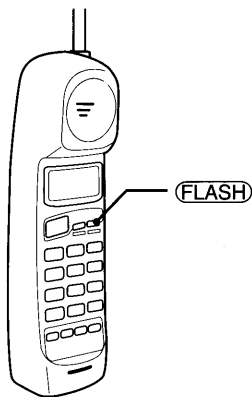

- 1** To answer a Call Waiting call, press the **(FLASH)** button.
- 2** Press the **(FLASH)** button again to switch between calls.

NOTES:

- Pressing the **(TALK)** button will not access Call Waiting; it will disconnect the current caller.
- Pressing the **(FLASH)** button without having received a Call Waiting signal may disconnect the current caller.

BANKING AND TELEPHONE SERVICES

Even if you have PULSE dialing, you can use this phone with banking and other phone services requiring touch tone signals.

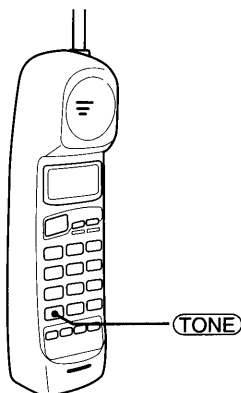

- 1** Dial the service number and wait for the connection.
- 2** Press the **(TONE)** button and then enter the numbers required.
- 3** You will hear the dial tones on the line.

PAGING THE HANDSET

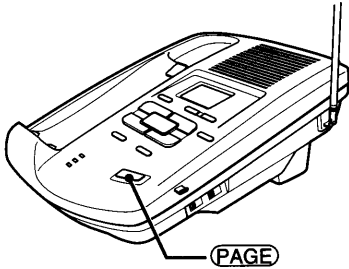

Press the **(PAGE)** button.

The paging signal is heard from the handset. When you press the **(PAGE)** button for a moment, the paging signal sounds for 15 seconds. To stop paging signal, press the **(PAGE)** button again.

NOTE:

If a call comes in during paging, you will hear the ring.

MEMORY DIAL

Numbers that are called a lot can be stored in memory and dialed by pressing only three buttons, reducing the amount of manual dialing.

You can store up to 20 telephone numbers in the speed dial memory. Each number can be up to 16 digits, including numbers and symbols (0-9, #, */TONE and PAUSE) which count 1 each.

STORING NUMBERS

Remember, each number should be stored just as you would dial it manually. So for long distance calls, you may need 1-area code-number.

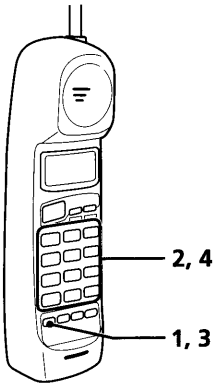

- 1 Press the **MEM** button.
- 2 Dial the phone number (16 digits max.).
- 3 Press the **MEM** button again.
- 4 Press the number (01-20) you want the phone number assigned to. A long beep indicates that the number has been stored successfully.

EXAMPLE to store (101)555-1234 under 02.

MEM → 1 0 1 5 5 5 1 2 3 4 → **MEM** → 0 2

EXAMPLE for storing a phone number and instructions for banking or voice mail systems in memory number 09:

Phone number Instructions
MEM → 9 0 1 2 3 4 5 → **RDL/P** → 6 7 8 9 1 2 → **MEM** → 0 9

NOTES:

- Each button must be pressed within 30 seconds after the previous button. Otherwise the storing procedure will be canceled.
- If you store a new telephone number in the same memory address, the previously stored telephone number will be erased.
- If you make a mistake, short beeps sound and the setting is canceled.

MEMORY DIAL

DIALING A STORED NUMBER

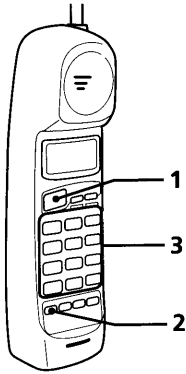

- 1 Press **TALK** and wait for dial tone.
- 2 Press the **MEM** button.
- 3 Press the memory location number (01-20).

ERASING A STORED NUMBER

You can erase a number or simply store another one in its place. When you store a new phone number, the one previously stored in that memory is erased automatically. To erase a stored number:

- 1 Press the **MEM** button twice.
- 2 Press the memory location button (01-20).

USING THE MEMORY DIALING OR PBX

The **RDL/P** button allows you to insert a pause of about 2 seconds in the memory dialing to make an outgoing call through a PBX or a long distance service.

EXAMPLE: to store 0-1234567 to call through a PBX in memory number 01

MEM → 0 → **RDL/P** → 1 2 3 4 5 6 7 → **MEM** → 0 1

If more than 2 seconds are needed, press **RDL/P** twice.

To dial the above number

TALK → **MEM** → 0 1

This phone may not work with some kinds of digital PBX systems. If you require further operating instructions about memory dialing, call 1-800-631-3811.

USING THE ANSWERING MACHINE

SETTING THE CLOCK

The answering machine's clock starts when the AC adaptor cord is plugged in. However, it does not start with the actual time. The right time must be programmed in on the base unit.

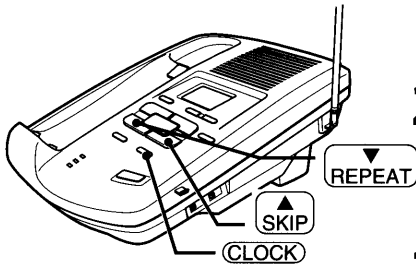

- 1** Press the **CLOCK** button for more than 2 seconds.
You will hear the beep sound to indicate that the unit is currently placed in the clock setting mode.
- 2** First select the day of a week by pressing the **▼** or **▲** button. When the number (corresponding to the day of a week you want to select) appears on the LED display, press the **CLOCK** button.
- 3** Next specify the Hour by pressing **▼** or **▲** button. If the numbers (01 - 12) you want appear in the LED display, press the **CLOCK** button.
- 4** Then specify the Minute by pressing **▼** or **▲** button. When the numbers (00 to 59) you want appear in the LED display, press the **CLOCK** button.
- 5** Lastly, specify AM/PM by pressing **▼** or **▲** button. The LED display will show AM and PM in turn. At the display you want, press the **CLOCK** button. You will hear a long beep.

Then you will hear the new day and time.

NOTES:

- You can hear the time currently set by pressing the **CLOCK** button.
- If a call comes in during clock setting, start over after the call.
- In case of power interruption, the clock stops, and you will need to reprogram the time once power is restored.

USING THE ANSWERING MACHINE

RECORDING THE OUTGOING MESSAGE (OGM)

You can record a personalized outgoing message or use the prerecorded electronic message. When a call is received, the answering machine answers the call and plays the OGM.

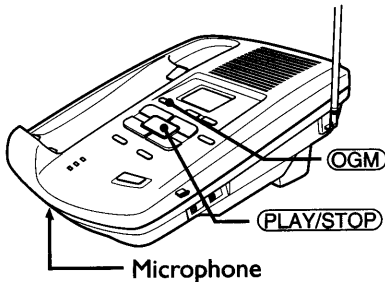

- 1** Press and hold the **OGM** button on the base unit for approximately 1 second.
After a long beep is heard, begin speaking over the microphone.
- 2** When you finish speaking, press the **OGM** or **PLAY/STOP** button.
The OGM just recorded will automatically be played back.

NOTES:

- If the OGM is shorter than 2 seconds, it will not be recorded.
- The maximum recording time for OGM is 30 seconds.

USING THE ANSWERING MACHINE

TURNING THE ANSWERING MACHINE ON & OFF

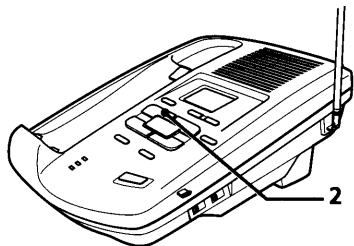

- 1** Check the LED display to see if the answering machine is on or off. If the LED display is on, the unit is on and ready to take messages. If the LED display is off, it will not take messages.
- 2** Simply press the **ANSWER** button to change the status from on to off or off to on. The LED display will indicate the change.
- 3** When the unit is turned on, it initializes by playing the outgoing message. If you want to stop playing, press the **PLAY/STOP** button.

TO CHANGE THE OUTGOING MESSAGE (OGM)

You can change from the pre-recorded OGM to your own recorded OGM or vice versa.

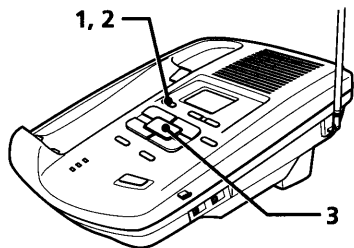

- 1** Press the **OGM** button on the base unit. You will hear the currently selected outgoing message.
- 2** Press the **OGM** button while the unit is playing the OGM.
- 3** Wait until the OGM is fully played back, or press the **PLAY/STOP** button. The OGM is then changed to another.

USING THE ANSWERING MACHINE

SETTING THE NUMBER OF RINGS

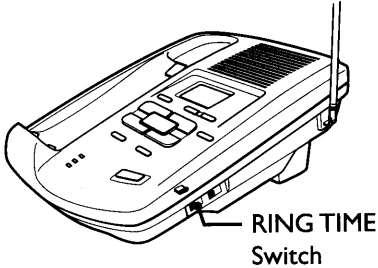

Choose one of three settings by sliding the RING TIME switch on the base unit to one of the following positions:

2: 2 times

4: 4 times

TS (TOLL SAVER MODE):

2 times when there are new messages, or 4 times there are no new messages.

SETTING MAXIMUM RECORDING TIME FOR INCOMING MESSAGES

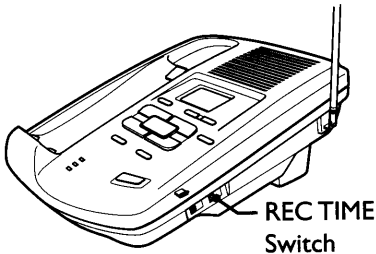

You can select the maximum recording time by sliding the REC TIME switch on the base unit to one of the following positions:

1: 1 minute

4: 4 minutes

ANN: Announce Only

NOTE:

If you set the switch to ANN, only the answer message will be announced and no message will be accepted.

USING THE ANSWERING MACHINE

PLAYING RECORDED MESSAGES

You can listen to messages at the base unit.

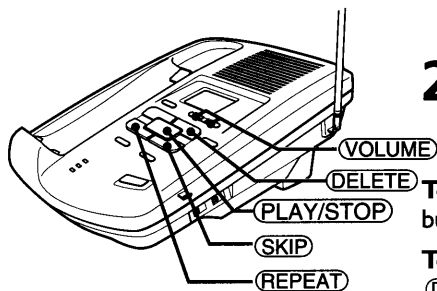

1 The number on the display will blink to indicate that new messages have been received.

2 Press the **PLAY/STOP** button to hear the messages. They will be played in the order they were received.

To stop playback, press the **PLAY/STOP** button again.

To delete individual messages, press the **DELETE** button for no longer than 1 second during playback, immediately after, or before the next message begins. You will hear a confirmation tone when the deletion is complete.

To delete all messages, press and hold the **DELETE** button at the BASE for more than 2 seconds. There will be one long beep to indicate successful deletion after playback is over.

To repeat the message, press the **REPEAT** button. To repeat the previous message, press **REPEAT** within 4.5 seconds after the current message has started. If you press after 4.5 seconds, the current message is repeated from the beginning.

To go backward and repeat a message you choose, press and hold the **REPEAT** button until your desired message number appears on the display.

To skip to the next message, press the **SKIP** button.

To go forward, press and hold the **SKIP** button until your desired message number appears on the display.

To adjust the speaker volume, press the **VOLUME** **-/+** buttons. The volume level is displayed by a figure from 1 to 10.

USING THE ANSWERING MACHINE

DELETING RECORDED MESSAGES

You can delete messages one at a time or all at once on the base unit.

To delete all messages:

Press and hold the **DELETE** button for 2 seconds.

A long confirmation beep sounds and all messages are deleted.

To delete individual messages:

During playing back the message you want to delete, press and hold the **DELETE** button approximately for 1 second.

A long confirmation beep sounds and the message is deleted.

NOTES:

- *If there are messages that you have not listened to when you are deleting all messages, you will hear several short beeps and the messages will not be deleted. This is to protect you from accidentally erasing messages you have not yet listened to.*
- *To maintain maximum available record time, it is a good idea to delete the old messages.*

SCREENING INCOMING CALLS

While the answering machine is taking messages, the incoming messages are heard from the base unit speaker.

If you wish to talk to the caller, follow the below.

When the handset is in its cradle on the base unit:

Pick up the handset and press the **TALK** button.

If you pick up the handset within 6 seconds after the answering has started, you can talk to the caller without pressing the **TALK** button.

When the handset is located away from the base unit:

Press the **TALK** button.

The answering machine will stop recording.

NOTE:

If the message portion was 2 seconds or less, it will not be retained as a message.

USING THE ANSWERING MACHINE

LEAVING A MEMO MESSAGE

You can record a memo by using the base unit, as a reminder to yourself or as a message for someone else in the household. A memo is stored and played back like any other incoming message, and the LED display will light to indicate that a message has been received. A memo can be recorded.

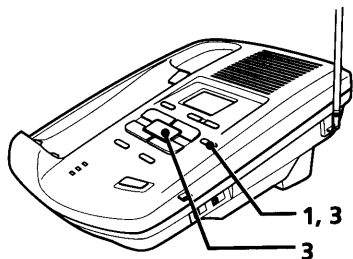

- 1** Press and hold the **MEMO** button approximately for 1 second.
- 2** After a long beep, turn to the microphone and begin speaking. Be sure to keep 11 to 20 inches away from the microphone while recording.
- 3** When you have finished the memo, press the **MEMO** button again, or the **PLAY/STOP** button.

NOTE:

If a call comes in during the memo recording, the unit will stop recording automatically and the ringer will sound. You will need to start over after the call. If the memo recording so far was more than 2 seconds, it will be retained as a message.

USING THE ANSWERING MACHINE

RECORDING A PHONE CONVERSATION (2WAY REC)

You can record a telephone conversation that is already in progress. The conversation is stored and played back like an incoming message.

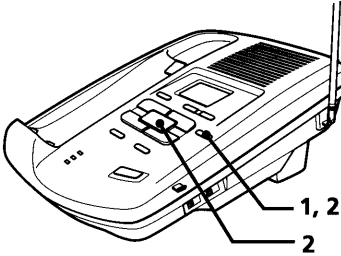

1 During the conversation via the handset, press and hold the **2WAY REC** button approximately for 1 second on the base unit. Recording starts automatically.

2 To stop recording, press the **2WAY REC** or **PLAY/STOP** button on the base unit.

NOTES:

- *If the recorded conversation is less than 2 seconds, it will be automatically deleted.*
- *The telephone beeps intermittently to alert the parties that the conversation is being recorded.*

REMOTE OPERATION

SETTING THE PIN NUMBER

In order to gain access to your answering machine when you are away from home, you need to identify yourself through the use of a Personal Identification Number (PIN). The PIN is preset to 80. You can select any two digit number between 00 and 99 as your PIN. To change your PIN, use the base unit.

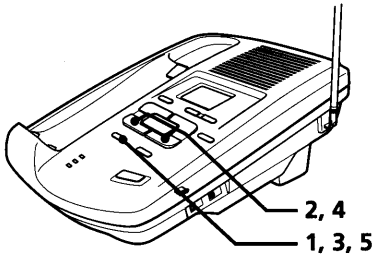

- 1** Press the **(PIN)** button for more than 2 seconds.
You will hear the beep sound to indicate that the unit is currently placed in the PIN setting mode.
- 2** Press the **▼** or **▲** button on the base unit to select the left digit of the PIN number.
- 3** If your desired number appears on the LED display, press the **(PIN)** button.
- 4** Press the **▼** or **▲** button to next select the right digit of the PIN number.
- 5** If your desired number appears on the LED display, press the **(PIN)** button.
- 6** The new PIN number you entered will be announced.

NOTE:

In the event of a long power failure, the PIN will revert to the 80 setting.

REMOTE OPERATION

CALLING IN FROM A REMOTE LOCATION

You can retrieve messages or change answering machine settings by calling the unit from a touch-tone phone. Even if the unit has been left off, you can still access it by turning it on first.

1 IF THE ANSWERING MACHINE IS OFF:

Let the phone ring at least 10 times. The line will connect and you will hear several short beeps. Press the **(#)** button and enter your PIN.

IF THE ANSWERING MACHINE IS ON:

After the answering machine begins playing your outgoing message, press the **(#)** button and enter your PIN.

2 The answering machine will announce the day and time and number of new and old messages. The answering machine will automatically start playing the new messages after announcing which messages it is going to play.

3 Press the **(#)** and **(2)** buttons to play old messages.

4 Press the **(#)** button and the appropriate number button that corresponds to the operation you want (see TABLE OF COMMANDS on next page).

5 When finished, press **(#)**, **(5)**, and hang up.

NOTES:

- *When entering your PIN number, the second digit must be entered within 2 seconds after the first one.*
- *If you enter a wrong PIN number 3 times, the line will be disconnected.*
- *Enter the command within 15 seconds or while you hear intermittent beeps. If you fail to enter a command in time, the line is disconnected.*
- *The playback stops after 4 minutes and if you do not enter the command within 15 seconds, the answering machine will disconnect the line. To continue listening, press the **(#)** and **(2)** buttons again.*
- *Make sure that the **(#)** and **(5)** buttons are pressed to stop each operation, if not so the line is not disconnected.*

REMOTE OPERATION

TABLE OF COMMANDS

OPERATION	KEYS
REPEAT	PRESS (#) (1)
PLAY	PRESS (#) (2)
SKIP	PRESS (#) (3)
INDIVIDUAL DELETE	PRESS (#) (4)
STOP	PRESS (#) (5)
ANSWER ON	PRESS (#) (6)
MEMO REC	PRESS (#) (7) *1
OGM REC	PRESS (#) (8)
ANSWER OFF	PRESS (#) (9)
ROOM MONITOR	PRESS (#) (*) *2

Notes: *1 The maximum recording time on your remote operation is 4 minutes.

2 This lasts for 15 seconds. (If you need another 15 seconds to monitor, press (#) () again.)

EXAMPLE

To playback:

Call your telephone and enter your PIN number during OGM playback.

To repeat:

Press (#) and (1) button during incoming message playback or the end of messages.

To record OGM:

Press (#), (5) and (#), (8) during incoming message playback.
Or press (#), (8) when incoming message does not playback.

ADDITION

CARRYING THE HANDSET IN THE BELT CLIP

You can attach the Belt Clip to the handset in order to carry it on your belt.

Attaching the Belt Clip to the Handset

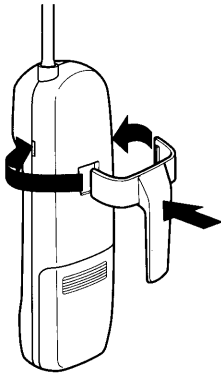

Insert the Belt Clip tabs into the holes on each side of the handset until they click.

NOTE:

Be sure to insert the tab properly into each hole to prevent the Belt Clip from falling off.

Removing the Belt Clip from the Handset

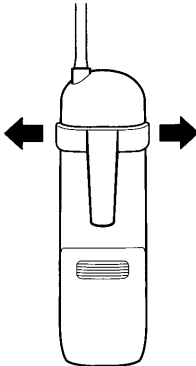

Pull both sides of the Belt Clip to release the tabs from the holes.

NOTE:

Remove the Belt Clip carefully from the handset, taking care not to hurt your fingers or damage your nails.

TROUBLESHOOTING

Should any problem occur with the set, make the following simple tests to determine whether or not servicing is required.

If the problem persists after you have made these tests, **call 1-800-631-3811 for Customer Service.**

PROBLEM	Cause and Countermeasure
No dial tone. No calls come in.	<ul style="list-style-type: none">• AC adaptor of the base unit is not plugged into the AC 120V outlet.• Battery is low. → Place the handset on the base unit to recharge.• Telephone line cord is disconnected. → Check the wall telephone jack.• The previous call is not disconnected. → Press the (TALK) button to disconnect the line.• Trouble with the telephone line. → Check with another telephone. Outlet used is controlled by a wall switch in its OFF position. Relocate it to another outlet.
The line is noisy.	<ul style="list-style-type: none">• The handset is too far from the base unit. → Bring the handset near the base unit.• The battery is low. → Place the handset on the base unit to recharge.• The base unit is located in a place with high interference. → Relocate the base unit.• Interference from TV, appliances, etc. → Move away from the interference source.• May be line noise. → Check with another phone.
Battery pack goes low quickly.	<ul style="list-style-type: none">• The battery pack was not fully charged at the initial charging. First, disconnect the phone from the telephone line and press the (TALK) button. Set the handset aside for about 8 hours to discharge the battery. Charge the battery pack for 12 to 16 hours without any interruption.• To avoid Ni-Cd battery memory effect, be sure to charge only as needed.• Battery needs to be replaced.

TROUBLESHOOTING

<p>The message is incomplete.</p>	<ul style="list-style-type: none"> • The incoming message was longer than the recording time (1 or 4 minutes), or shorter than 2 seconds. • The memo message was shorter than 2 seconds. • The recording capacity became full during recording. • The phone was answered during recording.
<p>The answering machine does not respond to remote operation.</p>	<ul style="list-style-type: none"> • You are not calling from a touch tone phone. • The PIN number you entered was wrong. (See page 39.) There was a power interruption and PIN has reset to 80.
<p>The answering machine does not answer callers.</p>	<p>The recording capacity is full. In this case, the line will be connected after 10 rings. However, the answering machine will not answer with the OGM. You will hear intermittent beeps prompting you to enter your PIN number.</p>
<p>The clock is incorrect.</p>	<ul style="list-style-type: none"> • There was a power interruption. → Reset the time. (See page 31.)
<p>The unit operates abnormally.</p>	<p>Try in this order.</p> <ol style="list-style-type: none"> 1 Disconnect the AC adaptor. 2 After a few seconds, connect the AC adaptor again.
<p>The TALK/BATT LOW LED blinks and a short beep sounds every 4 seconds during the standby status.</p> <p>During a phone conversation on the handset, a short beep sounds every 4 seconds and the TALK/BATT LOW LED also blinks every 4 seconds.</p>	<p>Battery is low.</p> <ul style="list-style-type: none"> → Place the handset in its cradle on the base unit to recharge. → Replace the battery of the handset with the battery of the base unit.
<p>"E" flashes in the LED display.</p>	<p>Disconnect the AC power cord and connect again. If the trouble persists, call 1-800-631-3811 for Customer Service.</p>

If you want to reset the unit to the factory settings

You can cancel the OGM, PIN, and the clock settings by the following process.

- 1 Disconnect the AC adaptor and telephone line cord from the base unit.
Also remove the battery pack from the base unit.
Keep the AC adaptor connected to the wall outlet. Make sure that the telephone line cord remains disconnected during this procedure.
- 2 While pressing the **DELETE** button, plug the AC power adaptor into the base. Keep pressing the **DELETE** button for more than 4 seconds.

A beep sounds and "88" blinks in the LED display.

To resume using the unit, connect the telephone line cord and place the handset on the base unit.

Note:

If you turn on the unit again, "88" may flash.

SPECIFICATIONS

HANDSET

Frequency	904.2 ~ 925.8 MHz
Power Source	Customer Replaceable Ni-Cd Battery 600 mAh 3.6 V DC
Battery Life	7 days at Standby Mode, after proper initial charging cycle
Dimensions (H/W/D)	Approx. 7- ¹ / ₂ " X 2- ¹ / ₄ " X 1- ¹³ / ₁₆ " (190 × 57 × 45 mm) Antenna Length 2- ¹ / ₂ " (61 mm)
Weight	Approx. 9 oz (265 g)

BASE UNIT

Frequency	904.2 ~ 925.8 MHz
Power Source	AC 120 V 60 Hz/DC 9 V
Dimensions (H/W/D)	Approx. 3- ⁷ / ₈ " X 6- ³ / ₄ " X 9" (96 × 171 × 226 mm)
Weight	Approx. 1 lb 10 oz (735 g), battery pack included

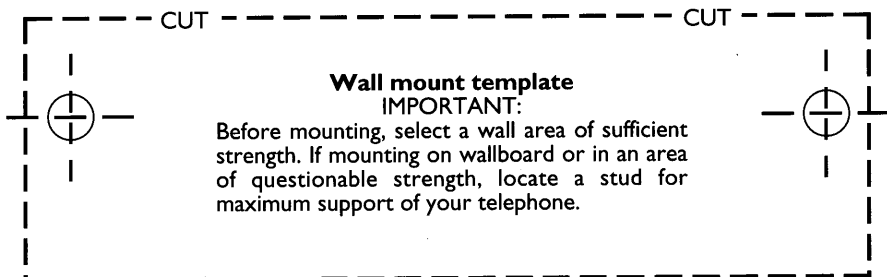

SPECIFICATIONS

SUPPLIED ACCESSORIES

Rechargeable Battery Pack	(2)	TRB-8258	Part #. RC005634
AC Adaptor	(1)	TAC-8908BK	Part #. RC008834
Short Modular Line Cord	(1)		Part #. RC001872
Long Modular Line Cord	(1)		Part #. RC001861
Speed Dial Index Card	(1)		Part #. RC008881
Desk Top/Wall Mount Bracket	(1)		Part #. RC005679
Wall Mount Screw	(2)		Part #. RC000936
Belt Clip	(1)		Part #. RC008880
Owner's manual	(1)		Part #. RC008882
Quick Reference Guide	(1)		Part #. RC008883

For the purchase of accessories, please call **1-800-631-3811**.

WARRANTY/SERVICE

SERVICE REQUIREMENTS

If the cordless telephone should malfunction, all repairs will be performed by an authorized Toshiba Service Station. This unit has been registered with the FCC for direct connection to the telephone network. Under the FCC program, no customer is authorized to repair this unit. This applies to both in and out of warranty. If an unauthorized repair is performed, the registration of the unit for direct connection to the network will be null and void. If the unit is still in warranty, the remainder of the warranty period will also be null and void.

It is the responsibility of users requiring service to report the need for service to the Toshiba dealer.

IMPORTANT INSTRUCTIONS TO USERS

Your SX-2908BK has been designed and constructed to conform to federal regulations and can be connected to the phone line as described in this manual.

Please note that each product connected to the telephone line places a certain load on the line. We designate this as the unit's "Ringer Equivalence Number."

It is most unlikely, but...If your SX-2908BK should cause problems on the phone line, the phone company has the right to temporarily discontinue your service. If this happens, the phone company will notify you and give you the opportunity to correct the problem. Also, you need to know that the phone company does have the right to make changes in their lines and/or equipment.

If these changes might affect your SX-2908BK (or require changes in the SX-2908BK or its connection), the phone company will notify you in writing, so you will have the chance to take whatever action necessary to ensure uninterrupted phone service.

FCC REQUIREMENTS

You are no longer required by the FCC to notify your local telephone company of your intent to connect a new telephone. Your local telephone company may call you and request information about your phone such as: the brand name, model number, registration number, and ringer equivalence number. This information is provided on a label located at the bottom of the base unit and handset.

You may not directly connect your SX-2908BK to coin telephone services. Check with your local telephone company if you wish to connect your SX-2908BK to a party line service. Some party line services require a special adaptor or modification to your telephone.

It should be noted that some cordless telephones operate at frequencies that may cause interference to nearby TVs and VCRs; to minimize or prevent such interference, the base of the cordless telephone should not be placed near or on top of a TV or VCR; and, if interference is experienced, moving the cordless telephone farther away from the TV or VCR will often reduce or eliminate the interference.

WARRANTY/SERVICE

TELEPHONE/TELEPHONE ANSWER MACHINE LIMITED WARRANTY

Toshiba America Consumer Products, Inc. ("TACP") and Toshiba Hawaii, Inc. ("THI") make the following limited warranties. These limited warranties extend to the original consumer purchaser or any person receiving this set as a gift from the original consumer purchaser and to no other purchaser or transferee.

Limited One (1) Year Warranty of Parts and Labor

TACP/THI warrant this product and its parts against defects in materials or workmanship for a period of one year after the date of original retail purchase. During this period, TACP/THI will repair a defective product or part without charge to you. You must deliver the entire unit to a TACP/THI Authorized Service Station. You are responsible for all transportation and insurance charges for the unit to and from the Authorized Service Station. If you live in the Continental U.S.A. you may, at your option, forward your product for exchange to:

Toshiba America Consumer Products, Inc.
Returns Center
1420C Toshiba Dr.
Lebanon, TN 37087

You are responsible for all transportation and insurance charges for the product to the Returns Center. Products shipped to the Return Center must be insured and safely and securely packed, preferably in the original shipping carton, and a letter explaining the defect and also a copy of the bill of sale or other proof of purchase must be enclosed.

Upon receipt we will, at our option, exchange the unit with a new or refurbished unit.

Owner's Manual

You should read the owner's manual thoroughly before operating this product.

Your Responsibility

The above warranties are subject to the following conditions.

(1) You must provide a copy of your bill of sale or other proof of purchase.

(2) These warranties are effective only if the product is purchased and operated within the U.S.A or Puerto Rico.

(3) Warranties extend only to defects in materials or workmanship as limited above and do not extend to any product or parts which have been lost or discarded by you or to damage to products or parts caused by misuse, accident, damage caused by Acts of God, such as lightning or fluctuations in electric power, improper installation, improper maintenance or use in violation of instructions furnished by us; or to units which have been altered or modified without authorization of TACP/THI or to damage to products or parts thereof which have had the serial number removed, altered, defaced or rendered illegible.

(4) At your option, after the warranty period has expired in the U.S.A., call (800)-631-3811 to receive information concerning an exchange price. Payment must be enclosed with the product in the form of a certified check or money order and forward with your product to:

Toshiba America Consumer Products, Inc.
Returns Center
1420C Toshiba Dr.
Lebanon, TN 37087

(5) Upon receipt we will, at our option, replace your unit with a new or refurbished unit of equal value. Features may not be identical to your original product.

(6) Physically damaged product are not acceptable for repair or exchange within or after the warranty period expires and will be returned as received.

(7) Any missing accessory components, (i.e., AC adaptor, line cord(s), battery, etc.), will be removed from the replacement unit being sent to you and packed with the defective unit you are returning.

WARRANTY/SERVICE

How to Obtain Warranty Service

In the event a problem should develop with your product, please proceed as follows:

(1) Arrange for the delivery of the product to the TACP/THI Authorized Service Station. Products Shipped to the Service Station must be insured and safely and securely packed, preferably in the original shipping carton, and a letter of explaining the defect and also a copy of the bill of sale or other proof of purchase must be enclosed. All transportation and insurance charges must be prepaid by you.

In The Continental United States contact: **In Hawaii contact:**



Toshiba Hawaii, Inc.
327 Kamakee Street,
Honolulu, HI 96814
(808)-521-5377

All warranties implied by state law, including the implied warranties of merchantability and fitness for a particular purpose, are expressly limited to the duration of the limited warranties set forth above. Some states do not allow limitations on how long an implied warranty lasts, so the above limitation may not apply to you. With the exception of any warranties implied by state law as hereby limited, the foregoing express warranty is exclusive and in lieu of all other warranties, guarantees, agreements and similar obligations of manufacturer or seller with respect to the repair or replacement of any product or parts.

In no event shall TACP or THI be liable for consequential or incidental damages. Some states do not allow the exclusion or limitation of incidental or consequential damages so the above limitation may not apply to you.

No person, agent, distributor, dealer, service station or company is authorized to change, modify or extend the terms of these warranties in any manner whatsoever. The time within which an action must be commenced to enforce any obligation of TACP and THI arising under this warranty or under any statute, or law of the United States or any state thereof, is hereby limited to one year from the date you discover or should have discovered, the defect. This limitation does not apply to implied warranties arising under state law. Some states do not permit limitation of the time within you may bring an action beyond the limits provided by state law so the above provision may not apply to you. This warranty gives you specific legal rights and you may also have other rights which vary from state to state.

IMPORTANT: PACKING AND SHIPPING INSTRUCTION

When you send the product to a service center, you should use the original carton box and packing material, then insert the original carton box containing the unit into another carton, using more packing material.

REMOTE OPERATION CARDS

CUT

TOSHIBA

REMOTE OPERATION OF SX-2908BK

- A** Call your machine from touch tone phone. After your machine answers, enter # and PIN (Access Code) pressing each digit for at least 1 second. If you enter # and PIN correctly, your machine sounds invitation tone after the announcement of the time and others. Now enter the command (# and number) by pressing the keypad.
- B** To playback incoming and memo messages, press #2. To skip, press #3 during playback. To repeat, press #1 during playback. To delete, press #4 during playback.
- C** To record MEMO message, press #7. To record OGM, press #8. To stop recording, press #5. To turn on the answer mode, press #6. To turn off the answer mode, press #9.
- D** To stop operation, press #5.

CORTE

TOSHIBA

OPERACIONES POR CONTROL REMOTO SX-2908BK

- A** Llame a su teléfono desde un teléfono de teclado. Después que su teléfono conteste, introduzca # y el código de acceso (PIN) presionando cada dígito durante 1 segundo como mínimo. Si introduce correctamente # y el PIN, su teléfono emitirá un tono de invitación después del anuncio de la hora y demás. Luego introduzca el mandato (# y un número) presionando las teclas.
- B** Para reproducir los mensajes recibidos y los memorandos presione #2. Para saltar presione #3 durante la reproducción. Para repetir presione #1 durante la reproducción. Para borrar presione #4 durante la reproducción.
- C** Para grabar mensajes de memorando presione #7. Para grabar un mensaje de contestación presione #8. Para detener la grabación presione #5. Para activar o desactivar el modo de contestación presione #6. Para desactivar el modo de contestación presione #9.
- D** Para detener la operación presione #5.

REMOTE OPERATION CARDS

CUT

TOLL FREE CUSTOMER SERVICE 1-800-631-3811

MESSAGE REPEAT # + 1	MESSAGE PLAYBACK # + 2	MESSAGE SKIP # + 3 (during playback)
MESSAGE DELETE # + 4 (during playback)	RECORD STOP/ OPERATION STOP # + 5	ANSWER ON # + 6
MEMO RECORD # + 7	OGM RECORD # + 8	ANSWER OFF # + 9
ROOM MONITOR # + *	0	REMOTE ACCESS # + PIN

CORTE

REPETICIÓN DE MENSAJE # + 1	REPRODUCCIÓN DE MENSAJE # + 2	SALTO DE MENSAJE # + 3 (durante la reproducción)
BORRADO DE MENSAJE # + 4 (durante la reproducción)	DETENCIÓN DE GRABACIÓN/OPERACIÓN # + 5	ACTIVACIÓN DE CONTESTACIÓN # + 6
GRABACIÓN DE MENSAJE DE MEMORANDO # + 7	GRABACIÓN DE MENSAJE DE CONTESTACIÓN # + 8	DESACTIVACIÓN DE CONTESTACIÓN # + 9
MONITOR DE SALA # + *	0	ACCESO AL CONTROL REMOTO # + PIN

For technical assistance, purchase of accessories or service, please call 1-800-631-3811.

IMPORTANT

We suggest you record the following information and retain for your records along with your bill of sale or equipment document.

Model no. _____ **Serial no.** _____
Purchase date _____ **Dealer** _____
Dealer address _____

© 1998 TOSHIBA AMERICA CONSUMER PRODUCTS, INC.