

### IC Recorder RR-DR60 Operating Instructions

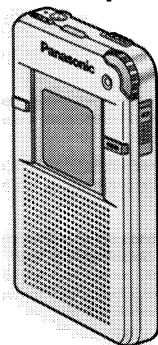

Before connecting, operating or adjusting this product, please read these instructions completely. Please save this manual.



En

Panasonic Consumer Electronics Company, Division of Matsushita Electric Corporation of America

One Panasonic Way Secaucus, New Jersey 07094

<http://www.panasonic.com>

Panasonic Sales Company, Division of Matsushita Electric of Puerto Rico, Inc. ("PSC")

Ave. 65 de Infantería, Km. 9.5 San Gabriel Industrial Park, Carolina, Puerto Rico 00985

Panasonic Canada Inc.

5770 Ambler Drive, Mississauga, Ontario L4W 2T3

[www.panasonic.ca](http://www.panasonic.ca)

RQT4606-1P

F0698R3078 (D)

## Specifications

<b>Power requirement:</b>	DC 3 V (two R03/LR03, AAA, UM-4 batteries)
<b>Power output:</b>	110 mW (max.)
<b>Output jack:</b>	Earphone $\varnothing$ 2.5 mm; 16 $\Omega$
<b>Speaker:</b>	2.8 cm (1 $\frac{1}{2}$ " ) 8 $\Omega$
<b>Dimensions (W×H×D):</b>	55.8×91.5×13.7 mm (2 $\frac{3}{16}$ "×3 $\frac{5}{8}$ "× $\frac{9}{16}$ " )
<b>Weight:</b>	
with batteries;	About 69 g (2.4 oz.)
without batteries;	About 46 g (1.6 oz.)

**Battery life:**  
[When used at 25°C (77°F) temperature and on a flat and stable surface]

Batteries	Playback	Recording
Panasonic alkaline batteries	About 8 hours	About 10 hours

•The battery life may be less depending on the operating conditions.

**Note**  
Specifications are subject to change without notice.  
Weight and dimensions are approximate.

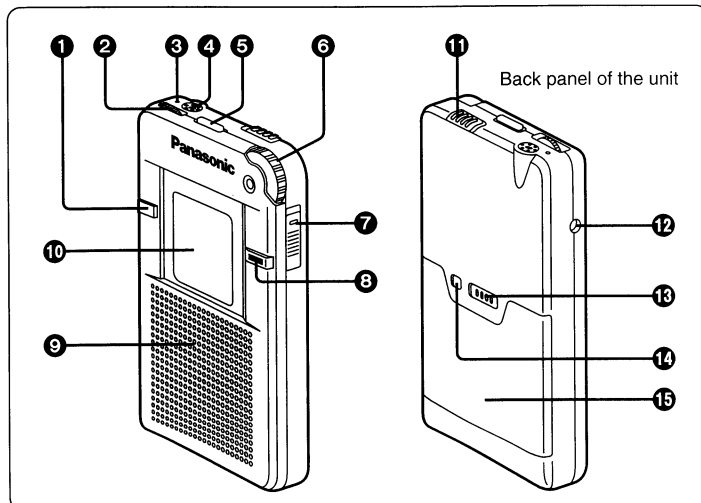

- 1 Mode button (MODE)
- 2 Volume control (VOL)
- 3 Recording lamp (REC)
- 4 Microphone (MIC)
- 5 Erase button (ERASE)
- 6 Play/select/stop dial (PLAY/SEL/STOP)
- 7 Hold switch (HOLD)
- 8 Recording start/stop button (REC START/STOP)
- 9 Speaker
- 10 Display screen (See below.)
- 11 Speed control switch (SPEED CONTROL)
  - Leave in the [OFF] position unless changing playback speed.
- 12 Earphone jack ( )
- 13 Mode select switch (MODE SELECT)
- 14 10 second review button (10 SEC REVIEW)
- 15 Battery cover

### The display screen

#### Normal display (while off)

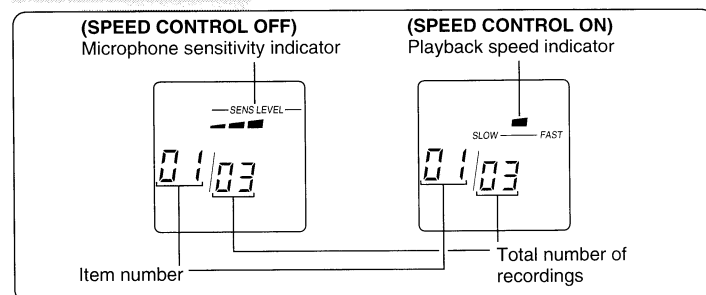

#### Recording display

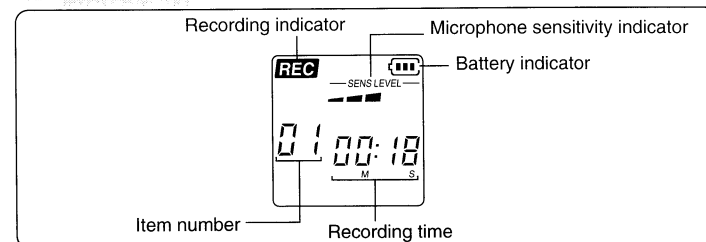

#### Playback display

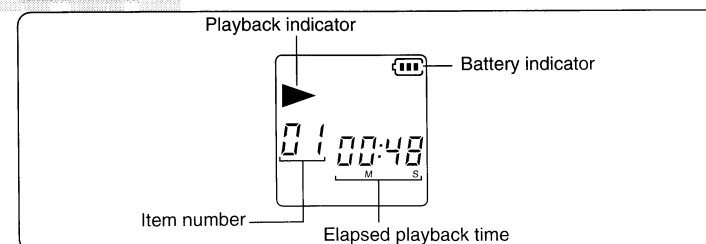

**Note**  
The display's liquid crystals can be affected by extremely high or low temperatures. The display may operate abnormally or speed may be affected, but normal operation is restored when the temperature returns to normal.

## Inserting the batteries

Insert two "AAA" (R03/LR03, UM-4) batteries (not included). Long life alkaline batteries are recommended. If rechargeable batteries are to be used, rechargeable batteries manufactured by Panasonic are recommended.

- 1 Slide the battery cover in the direction of the arrow.

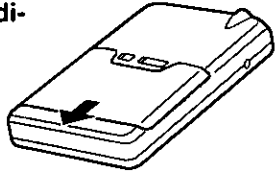

- 2 Insert two batteries (not included) and close the cover.

Insert batteries in the correct polarities (+, -).

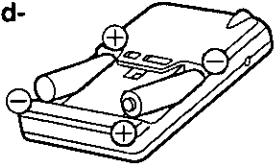

### After the batteries are inserted:

If the year starts flashing on the display after "good" is displayed, set the time so the unit can keep track of the time and date of recording. For details see "Setting the time" (page 4).

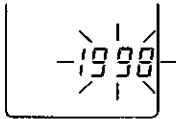

### Note

Do not press the buttons while inserting the batteries. This may cause malfunction of the unit or its display.

### To remove the batteries

Lift the batteries out in the direction of the arrow.

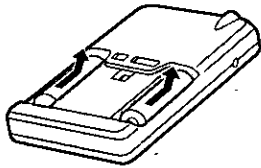

### Battery replacement

The battery indicator keeps track of the life left in the battery. Replace the batteries when "U01" is displayed.

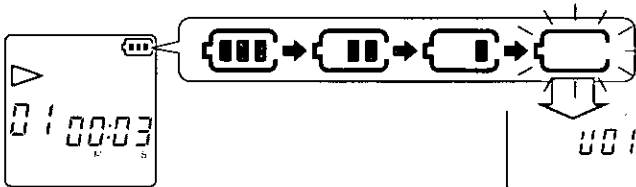

### Note

- The battery indicator is not shown while the recorder is stopped.
- This unit indicates that the batteries have run down when there is actually still some life left in them. This is to preserve the contents of the memory.
- Insert fresh batteries within about three minutes of removing the old ones. If the unit is left without batteries for longer than this, all settings revert to the conditions as at time of purchase. Reset the time if this occurs. Recordings remain unaffected.

## Hold function

This function prevents accidental operation of the unit and wear of the batteries.

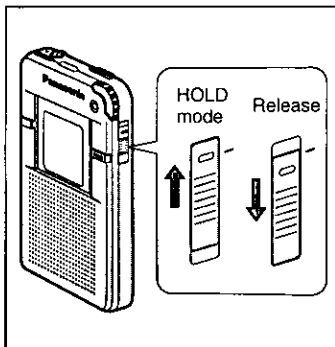

Slide [HOLD] to the HOLD position.

"HOLD" is displayed on the screen and the buttons do not respond when pressed.

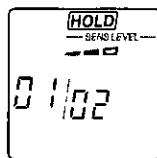

Release HOLD before attempting any operation.

## Setting the time

Set the time so the unit can keep a record of when recordings are made.

When batteries are inserted for the first time or the year display flashes after inserting fresh batteries;

### 2 Set the time

- 1 Turn [PLAY/SEL/STOP] to select 12 or 24 hour time display.

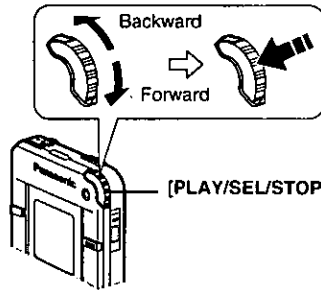

- 2 Press [PLAY/SEL/STOP]. The time display appears flashing.



(e.g. if the 24 hour display is selected)

- 3 Turn [PLAY/SEL/STOP] to set the time



### 1 Set the date

- 1 Turn [PLAY/SEL/STOP] to set the year.

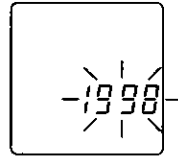

- 2 Press [PLAY/SEL/STOP]. The month display appears flashing.

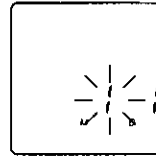

- 3 Repeat 1 and 2 to set the month and day in turn. "12H" appears flashing.

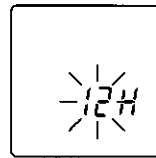

- 4 Press [PLAY/SEL/STOP]. The clock is now set. The screen shows the normal (off) display.

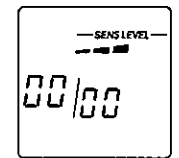

If the screen shows the normal display before the clock has been correctly set:

- 1 Slide [MODE SELECT] to the [CLOCK/MIC SET] position.
- 2 Press [MODE] twice. The year display appears flashing. Start again at step 1 above.

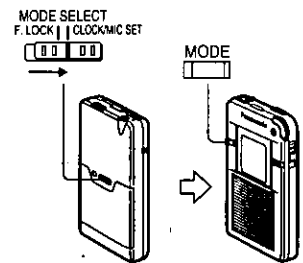

### Checking and resetting the clock

- 1 Slide [MODE SELECT] to the [CLOCK/MIC SET] position.
- 2 Press [MODE] twice.

The year appears on the screen.

The display changes as follows each time [MODE] is pressed:

Month/day  
↓  
Time display mode (12 or 24 hour display)  
↓  
Time  
↓  
Normal display

When the item you want to change is displayed, turn [PLAY/SEL/STOP] to set the required value.

### Note

This unit is unable to display the time constantly.

## Recording

Ninety-nine different items with a total of sixty minutes can be recorded. The newest recording is automatically added to the end, so recording is more economic and speedy as there is no need to search for available space.

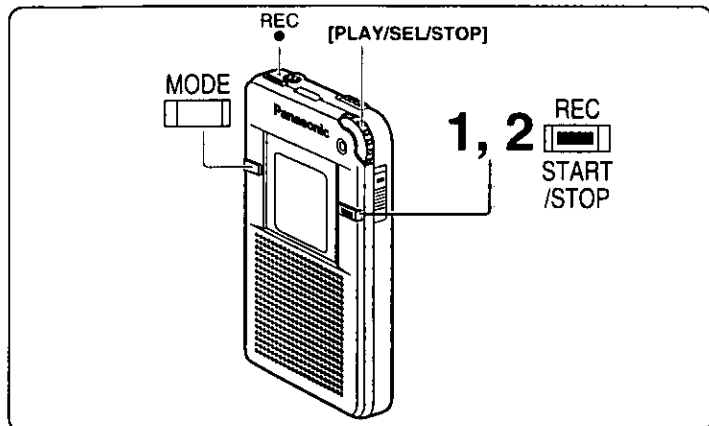

### 1 Press [REC START/STOP]. (Recording starts.)

[REC] lamp lights, and the recording indicator "REC" is shown on the display.

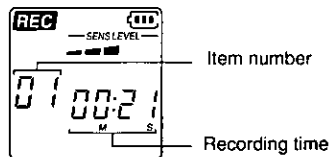

### 2 Press [REC START/STOP] again. (Recording stops.)

The display changes in the following order:

- ① Date of recording
- ② Time of recording
- ③ Length of recording
- ④ Normal display (ready to playback the recording)

#### To playback just after recording

After stopping recording, press [PLAY/SEL/STOP].

#### Microphone sensitivity

There are five levels of sensitivity. (The level is factory set to 3.) See page 9 for details on how to change the setting.

#### VAS (Voice activated system)

Recording automatically pauses when no sound is detected. This avoids blank portions in recordings. The function works better the lower the microphone sensitivity level (see page 9).

[REC] lamp flashes when VAS works and recording stops temporarily.

#### To check the available recording time

Press [MODE] once while recording. The display shows the time available as a negative figure, e.g. "-9:35".

Press again to return to the previous display.

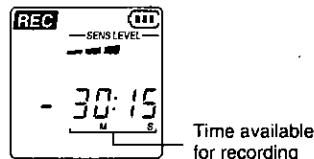

#### When time available for recording is getting short

- Once the available time goes below 10 minutes, the display shows the available time as a negative figure, e.g. "-9:35".
- If 99 different items or a total of 60 minutes have been recorded, "FULL" flashes on the screen when [REC START/STOP] is pressed, and recording will not start. Erase any unneeded items before continuing. (See page 7 for details on how to erase items.)

#### Note

The recorder is full if either 60 minutes or 99 items is reached.

Test the unit before making important recordings. No responsibility can be taken for recordings not made due to malfunction of the IC recorder.

## Playback

Start at step 1 if recalling a prior recording. Start at step 2 if playing back a recording just made.

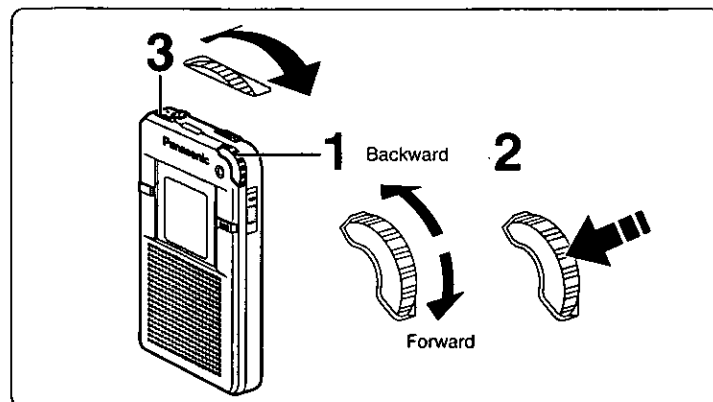

### 1 Turn [PLAY/SEL/STOP] to display the item you want to listen to.

Information about the selected item appears in the following order:

- ① Date of recording
- ② Time of recording
- ③ Length of recording
- ④ Normal display (ready to playback the recording)

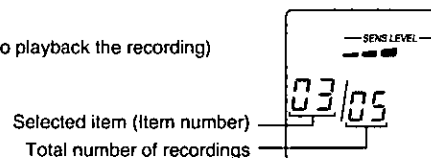

### 2 Press [PLAY/SEL/STOP] to playback.

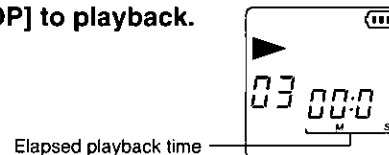

### 3 Adjust the volume.

One item is played back and the unit stops at the beginning of the next item.

#### To stop playback

Press [PLAY/SEL/STOP].

Pressing [PLAY/SEL/STOP] again starts playback from the point it was stopped at.

#### To proceed to the next item during playback

Turn [PLAY/SEL/STOP] downward (forward) slowly.

#### To return to the beginning of the item playing back

Turn [PLAY/SEL/STOP] upward (backward) slowly. If this is done within three seconds from the start of the item, playback starts from the beginning of the previous item.

#### To fast-forward/rewind

Turn [PLAY/SEL/STOP] rapidly during playback. The unit fast-forwards or rewinds in 10 second intervals. This functions only within items.

#### Intro-scan playback

##### (Listening to the beginning of each item)

Press and hold [PLAY/SEL/STOP] while stopped for a moment.

The first four seconds of each item is played in order from the first item.

If you want to listen to an item in full, press [PLAY/SEL/STOP] while it is playing.

#### Skipping back 10 seconds during playback

Press [10 SEC REVIEW] during playback.

Playback skips 10 seconds back.

This functions only within items.

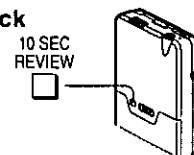

#### Using earphone (not included)

Use a monaural type if you want to listen with an earphone. Insert the earphone plug into the earphone jack. (Plug in firmly.) The impedance must be 16Ω or higher for Mono earphone and 32Ω for stereo earphones (with Mono conversion adaptor). Plug type: 2.5 mm super mini  
Sound will not be heard from the speaker.

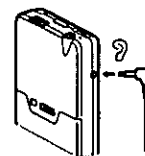

#### Changing the playback speed

There are five levels of playback speed. (The level is factory set to 3.) See page 10 for details on how to change the setting.

## Erasing items

Items can either be erased one by one or all at once. Erased items cannot be recalled.

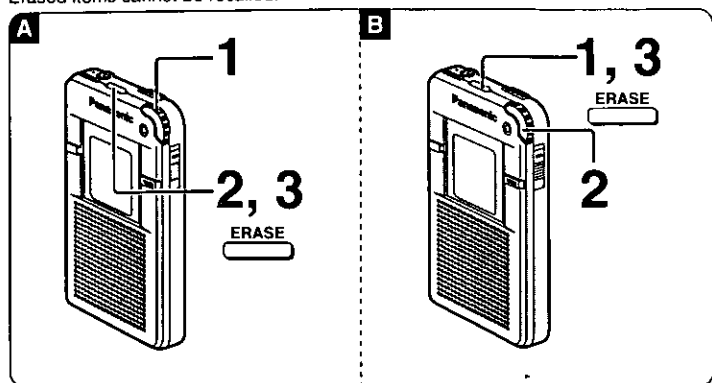

### Erasing one item

Erase while playing the item to be erased or stopped:

**1** If stopped, turn [PLAY/SEL/STOP] to display the number of item to be erased.

**2** Press and hold [ERASE] for a moment.

"ERASE" appears on the display and the item number flashes.

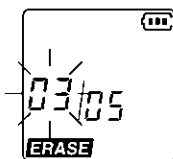

**3** Press [ERASE] while the number is flashing.

The item is erased. Any items after the erased item move down to take its place. There are no missing numbers after an item is erased.

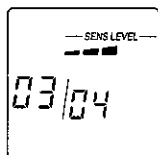

#### Canceling the erase mode

Press [PLAY/SEL/STOP] before step 3.

### Erasing all items

**1** Press and hold [ERASE] for a moment while stopped or playing.

"ERASE" appears on the screen and the item number flashes.

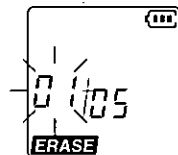

**2** Turn [PLAY/SEL/STOP] until "ALL" appears on the display.

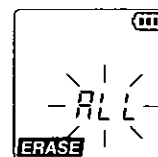

**3** Press [ERASE] while "ALL" is flashing.

All items are erased.

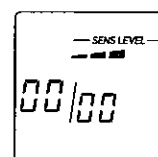

#### Canceling the erase mode

Press [PLAY/SEL/STOP] before step 2 or 3.

#### Note

Locked items are not erased. (See page 8)

## Erasure prevention (Locking items)

Lock individual recordings to avoid accidentally erasing them.

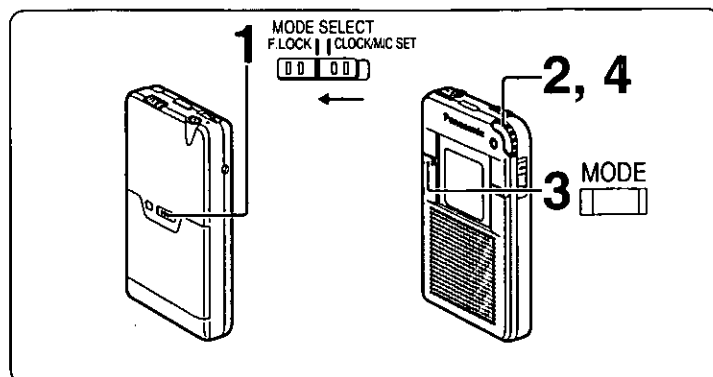

Lock while playing the item to be locked or stopped:

**1** Slide [MODE SELECT] to the [F.LOCK] position.

**2** If stopped, turn [PLAY/SEL/STOP] to display the number of item to be locked.

**3** Press [MODE].

The item number and "LOCK" flash.

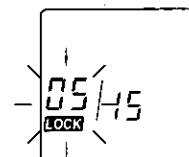

**4** Press [PLAY/SEL/STOP] while they are flashing.

The item is locked.

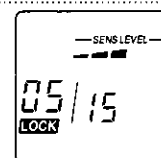

#### Canceling the lock mode

Press [MODE] before step 4.

### Unlocking an item

Unlock while playing the item to be unlocked or stopped:

**1** Slide [MODE SELECT] to the [F.LOCK] position.

**2** If stopped, turn [PLAY/SEL/STOP] to display the number of item to be unlocked.

**3** Press [MODE].

"LOCK" flashes.



**4** Press [PLAY/SEL/STOP] while "LOCK" is flashing.

The item is unlocked.

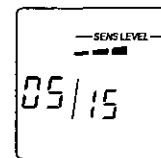

#### Canceling the unlocking mode

Press [MODE] before step 4.

## Changing microphone sensitivity

Five levels of sensitivity can be selected to suit different conditions.  
(The setting is 3 at time of purchase.)

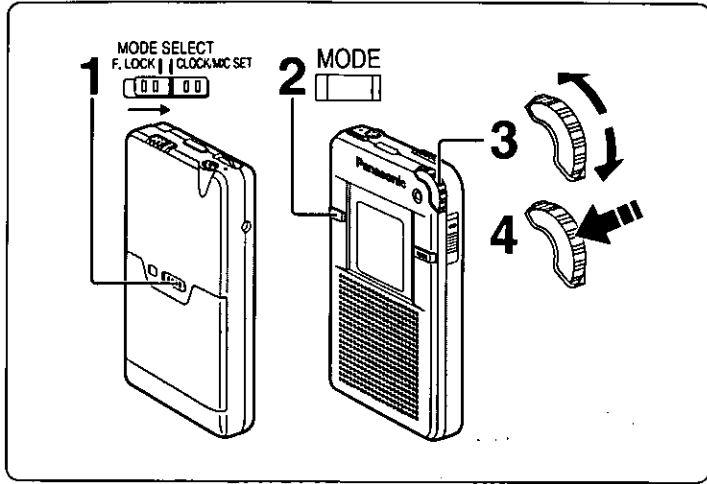

**1** While stopped, slide [MODE SELECT] to the [CLOCK/MIC SET] position.

**2** Press [MODE] once.  
"SENS LEVEL" flashes.



**3** While it is flashing, turn [PLAY/SEL/STOP] to select the required level.  
The sensitivity indicator flashes.

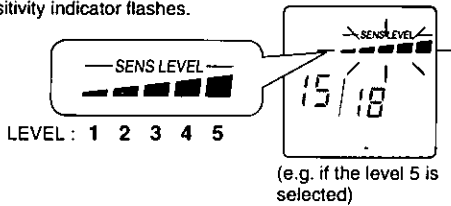

- LEVEL 1-2: If you wish to record only the louder sounds.
- LEVEL 3: If you wish to record normal level sounds.
- LEVEL 4-5: If you wish to record lower levels of sound than usual.

**4** While it is flashing, press [PLAY/SEL/STOP].  
The sensitivity is selected.

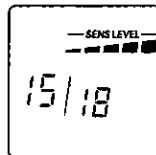

## Changing playback speed

There are five playback speeds.  
(The setting is 3 at time of purchase.)

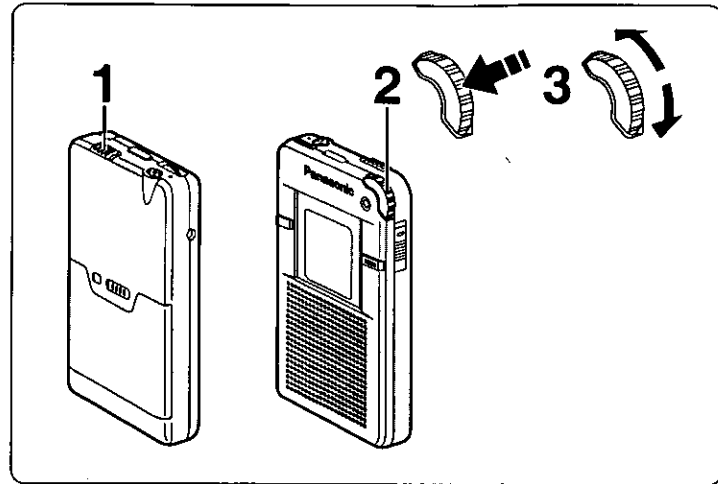

**1** Slide [SPEED CONTROL] to the [ON] position while stopped.  
The playback speed indicator appears.



**2** Press [PLAY/SEL/STOP] to playback an item.  
The playback speed indicator flashes.

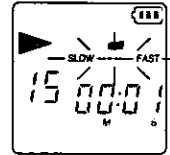

**3** Turn [PLAY/SEL/STOP] to select the required speed.

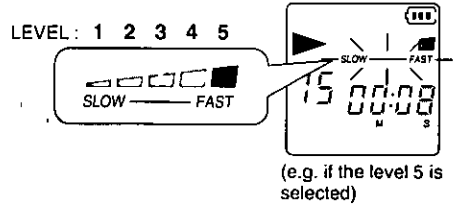

**Note**  
Playback speed can only be changed during playback.

## Troubleshooting Guide

Before requesting service for this unit, check the chart below for a possible cause of the problem you are experiencing. Some simple checks or a minor adjustment on your part may eliminate the problem and restore proper operation.

If you are in doubt about some of the check points, or if the remedies indicated in the chart do not solve the problem, refer to the directory of Authorized Service Centers (enclosed with this unit) to locate a convenient service center, or consult your dealer for instructions.

**For detailed instructions, contact an authorized servicer in the U.S.A. and Panasonic Canada Inc. Customer Care Center in Canada.**  
**In the U.S.A. 1-800-211-7262 or web site (<http://www.panasonic.com>)**  
**In Canada 905-624-5505 or web site ([www.panasonic.ca/faq.html](http://www.panasonic.ca/faq.html))**

Symptom	Checkpoints
Unit doesn't operate	<ul style="list-style-type: none"> <li>Is HOLD on?</li> </ul>
No sound from the speaker	<ul style="list-style-type: none"> <li>Is earphone (not included) connected?</li> <li>Is the volume turned down?</li> </ul>
When using earphone (not included), there is no sound or it is difficult to hear or there is noise	<ul style="list-style-type: none"> <li>Is the earphone plug fully inserted?</li> <li>Is the plug dirty? (Wipe away dirt on plug.)</li> </ul>
"U01" appears on the display	<ul style="list-style-type: none"> <li>Have the batteries run down?</li> </ul>
Recording stops	<ul style="list-style-type: none"> <li>Has VAS (page 5) functioned?</li> </ul>
The date of recording appears as "----"	<ul style="list-style-type: none"> <li>Has the time been set? (The date of recording is not displayed unless the time has been set.)</li> </ul>
Playback speed is too fast or slow	<ul style="list-style-type: none"> <li>Has playback speed been changed? (See page 10 to set to the required speed.)</li> </ul>
"FULL" appears when trying to make a recording	<ul style="list-style-type: none"> <li>Have 99 items been recorded?</li> <li>Have 60 minutes worth of recordings been made?</li> </ul>
After inserting the batteries, "Sorry" appears on the display.	<ul style="list-style-type: none"> <li>Has the unit been left unused for a long time? Reset the unit by reinserting the batteries while pressing and holding down [MODE] and [PLAY/SEL/STOP]. All recordings are erased at this time.</li> </ul>

## Care and Use

### Unit

- Avoid using or placing this unit near sources of heat. Do not leave it in an automobile exposed to direct sunlight for a long period of time with the doors and windows closed.
- To avoid product damage, do not expose this product to rain, water or other liquids.
- Do not keep this unit and magnetized cards (bank cards, commuter passes, etc.) close together

### Dry cell battery

- Load the new batteries with their polarities (+ and -) aligned correctly.
- Do not apply heat to batteries, or internal shortcircuit may occur.
- If this unit is not to be used for a long period of time, remove the batteries and store them in a cool and dry place.
- Remove spent batteries immediately.

### Listening caution



Do not play your headphones or earphone at a high volume. Hearing experts advise against continuous extended play.

If you experience a ringing in your ears, reduce volume or discontinue use. Do not use while operating a motorized vehicle. It may create a traffic hazard and is illegal in many areas.

You should use extreme caution or temporarily discontinue use in potentially hazardous situations.

Even if your headphones or earphone is an open-air type designed to let you hear outside sounds, don't turn up the volume so high that you can't hear what's around you.

Sound can be deceiving. Over time your hearing "comfort level" adapts to higher volumes of sound. So what sounds "normal" can actually be loud and harmful to your hearing.

Guard against this by setting your equipment at a safe level BEFORE your hearing adapts.

To establish a safe level:

- Start your volume control at a low setting.
- Slowly increase the sound until you can hear it comfortably and clearly, and without distortion.

Once you have established a comfortable sound level:

- Set the dial and leave it there.

## Product Service

Do not attempt to remove the cover(s) or repair the unit yourself. Refer servicing to qualified personnel only.

### Product information

For product service, product information or assistance with product operation, refer to the servicer directory.

### User memo:

DATE OF PURCHASE \_\_\_\_\_  
 DEALER NAME \_\_\_\_\_  
 DEALER ADDRESS \_\_\_\_\_  
 TELEPHONE NUMBER \_\_\_\_\_

The serial number of this product can be found inside of the battery compartment. Please note them in the space provided below and keep as a permanent record of your purchase to aid identification in the event of theft.

MODEL NUMBER \_\_\_\_\_  
 SERIAL NUMBER \_\_\_\_\_

## Maintenance

Clean with a soft cloth. For very dirty surfaces clean with a mild dish washing liquid, then wipe with a dry cloth. Do not use alcohol or thinners to clean this unit.

### THE FOLLOWING APPLIES ONLY IN THE U.S.A.

### CAUTION:

This equipment has been tested and found to comply with the limits for a Class B digital device, pursuant to Part 15 of the FCC Rules.

These limits are designed to provide reasonable protection against harmful interference in a residential installation. This equipment generates, uses and can radiate radio frequency energy and, if not installed and used in accordance with the instructions, may cause harmful interference to radio communications. However, there is no guarantee that interference will not occur in a particular installation. If this equipment does cause harmful interference to radio or television reception, which can be determined by turning the equipment off and on, the user is encouraged to try to correct the interference by one of the following measures:

- Reorient or relocate the receiving antenna.
- Increase the separation between the equipment and receiver.
- Connect the equipment into an outlet on a circuit different from that to which the receiver is connected.
- Consult the dealer or an experienced radio/TV technician for help.

Any unauthorized changes or modifications to this equipment would void the user's authority to operate this device.

This device complies with Part 15 of the FCC Rules. Operation is subject to the following two conditions: (1) This device may not cause harmful interference, and (2) this device must accept any interference received, including interference that may cause undesired operation.

Panasonic Consumer Electronics Company, Division of Matsushita Electric Corporation of America One Panasonic Way, Secaucus, New Jersey 07094

Panasonic Sales Company, Division of Matsushita Electric of Puerto Rico, Inc. ("PSC") Ave. 65 de Infernaria, Km. 9.5 San Gabriel Industrial Park Carolina, Puerto Rico 00985 Tel. (809) 750-4300 FAX. (809) 768-2910

# Panasonic Audio Products Limited Warranty

Panasonic Consumer Electronics Company or Panasonic Sales Company (collectively referred to as "The warrantor") will repair this product with new or refurbished parts, free of charge, in the U.S.A. or Puerto Rico from the date of original purchase in the event of a defect in materials or workmanship as follows:

**AUDIO COMPONENTS, RADIOS, COMPACT DISC PLAYERS, VIDEO CD PLAYERS AND HOME ENTERTAINMENT SYSTEMS**—For one (1) year.

**ACCESSORIES, HEADPHONES AND CARTRIDGES**—(when applicable) For ninety (90) days.

**BATTERIES**—(when applicable)—New rechargeable batteries in exchange for defective rechargeable batteries—For ten (10) days. Non-rechargeable batteries are not warranted.

**RECHARGEABLE BATTERY PACKS**—(when applicable)—New rechargeable battery packs in exchange for defective rechargeable battery packs for (90) days. Non-rechargeable battery packs are not warranted.

Carry-in or mail-in service in the continental U.S.A. can be obtained during the warranty period from a Panasonic Services Company (PASC) Factory Servicenter listed in the Servicenter Directory. Or call 1-800-211-7262, toll free, to locate an authorized PASC Servicenter. Carry-in or mail-in service in Puerto Rico can be obtained during the warranty period by calling the telephone numbers listed in the Servicenter Directory.

This warranty is extended only to the original purchaser. A purchase receipt or other proof of date of original purchase will be required before warranty service is rendered.

This warranty only covers failures due to defects in materials or workmanship

which occur during normal use and does not cover normal wear to the stylus (when applicable) or dealer installed cartridge or stylus. It does not cover damage which occurs in shipment or failures which are caused by products not supplied by the warrantor or failures which result from accident, misuse, abuse, neglect, mishandling, misapplication, faulty installation, set-up adjustment, improper maintenance, alteration, improper antenna, inadequate signal pick-up, maladjustment of consumer controls, modification, or commercial use of product, or service by anyone other than a PASC Factory Servicenter or authorized PASC Servicenter, or damage that is attributable to acts of God.

### LIMITS AND EXCLUSIONS

There are no express warranties except as listed above.

THE WARRANTOR SHALL NOT BE LIABLE FOR INCIDENTAL OR CONSEQUENTIAL DAMAGES RESULTING FROM THE USE OF THIS PRODUCT, OR ARISING OUT OF ANY BREACH OF THIS WARRANTY, INCLUDING WITHOUT LIMITATION, DAMAGE TO TAPES RECORDS OR DISCS. ALL EXPRESS AND IMPLIED WARRANTIES INCLUDING THE WARRANTIES OF MERCHANTABILITY AND FITNESS FOR A PARTICULAR PURPOSE, ARE LIMITED TO THE APPLICABLE WARRANTY PERIOD SET FORTH ABOVE. Some states do not allow the exclusion or limitation of incidental or consequential damages, or limitations on how long an implied warranty lasts, so the above exclusions or limitations may not apply to you.

This warranty gives you specific legal rights and you may also have other rights which vary from state to state.

If a problem with this product develops during or after the warranty period, you may contact your dealer or Servicenter. If the problem is not handled to your satisfaction, then write to the Consumer Affairs Division at the company address indicated above.

### If you ship the product

Carefully pack and send it prepaid, adequately insured and preferably in the original carton. Attach a postage-affixed letter, detailing the complaint, to the outside of the carton.

*Do NOT send the product to the Executive or Regional Sales offices. They are NOT equipped to make repairs.*

### Customer's Record

Model No. \_\_\_\_\_

Dealer's Name \_\_\_\_\_

Serial No. \_\_\_\_\_  
or \_\_\_\_\_

Code No. \_\_\_\_\_

Dealer's Address \_\_\_\_\_

Date of Purchase \_\_\_\_\_

**For Product Information, Operating Assistance, Literature Request, Dealer Locations, and all Customer Service inquiries please contact:  
800-211-PANA (7262), Monday-Friday 9 am-9 pm Saturday-Sunday 9 am-7 pm, EST.**

**Web Site: <http://WWW.Panasonic.com>  
You can purchase parts, accessories or locate your nearest servicenter by visiting our Web Site.**

**Accessory Purchases:**

**1-800-332-5368 (Customer Orders Only)  
Panasonic Services Company 20421 84th Avenue South, Kent, WA 98032  
(6 am to 5 am Monday-Friday; 6 am to 10:30 am Saturday; PST)  
(Visa, MasterCard, Discover Card American Express, Check)**

**Factory Servicenters Locations**

<p><b>CALIFORNIA</b> 6550 Katella Avenue Cypress, CA 90630</p> <p>800 Dubuque Avenue S. San Francisco CA 94080</p> <p>20201 Sherman Way Suite 102 Canoga Park, CA 91306</p> <p>3878 Ruffin Road Suite A San Diego, CA 92123</p> <p><b>COLORADO</b> 1640 South Abilene Street Suite D Aurora, CO 80012</p> <p><b>FLORIDA</b> 3700 North 29<sup>th</sup> Avenue Suite 102 Hollywood, FL 33020</p>	<p><b>GEORGIA</b> 8655 Roswell Road Suite 100 Atlanta, GA 30350</p> <p><b>ILLINOIS</b> 1703 North Randall Road Elgin, IL 60123 (Pick-up/Drop-off only)</p> <p>9060 Golf Road Niles, IL 60714</p> <p><b>MARYLAND</b> 62 Mountain Road Glen Burnie, MD 21061</p> <p><b>MASSACHUSETTS</b> 60 Glacier Drive Suite G Westwood, MA 02090</p>	<p><b>MICHIGAN</b> 37048 Van Dyke Avenue Sterling Heights, MI 48312</p> <p><b>MINNESOTA</b> 7850-12<sup>th</sup> Avenue South Airport Business Center Bloomington, MN. 55425</p> <p><b>OHIO</b> 2236 Waycross Road Civic Center Plaza Forest Park, OH 45240</p> <p><b>PENNSYLVANIA</b> 2221 Cabot Blvd. West Suite B Langhorne, PA 19047</p> <p>Chartiers Valley Shopping Center 1025 Washington Pike Bridgeville, PA 15017</p>	<p><b>TENNESSEE</b> 919-8<sup>th</sup> Avenue South Nashville, TN 37203</p> <p><b>TEXAS</b> 7482 Harwin Drive Houston, TX 77036</p> <p>13615 Welch Road Suite 101 Farmers Branch, TX 75244</p> <p><b>WASHINGTON</b> 20425-84<sup>th</sup> Avenue South Kent, WA 98032</p> <p><b>HAWAII</b> 99-859 Iwaiwa Street Aiea, Hawaii 96701 Phone (808) 488-1996 Fax (808) 486-4369</p>
---	--	---	--

**Service in Puerto Rico**

**Matsushita Electric of Puerto Rico, Inc. Panasonic Sales Company/Factory Servicenter.  
Ave. 65 de Infantería, Km. 9.5, San Gabriel Industrial Park, Carolina, Puerto Rico 00985  
Phone (787) 750-4300 Fax (787) 768-2910**