

# ICF-C26

## SERVICE MANUAL

AEP Model  
UK Model

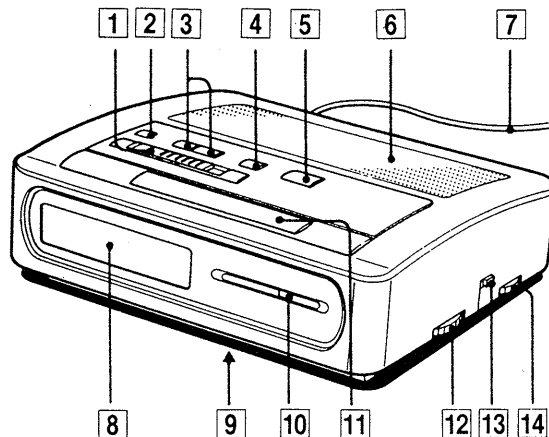

### SPECIFICATIONS

Frequency range

	FM	AM
AEP, UK, G model	87.6 – 107.5 MHz	531 – 1,602 kHz
IT model	87.5 – 108 MHz	526.5 – 1,606.5 kHz
EE model	65 – 108 MHz	531 – 1,602 kHz

Antennas	FM: AC power cord antenna AM: Built-in ferrite bar antenna
Speaker	Approx. 6.6 cm (2 <sup>5</sup> / <sub>8</sub> inches) dia.
Power output	100 mW (at 10% harmonic distortion)
Power requirements	220 V AC, 50 Hz (AEP, IT, G, EE model) 240 V AC, 50 Hz (UK model) For the power back-up function: 9 V DC, one 6F22 battery
Battery life	Approx. 80 hours, using Sony battery S-006P (U)
Dimensions	Approx. 181.5 × 59 × 144 mm (w/h/d) (7 <sup>1</sup> / <sub>4</sub> × 2 <sup>3</sup> / <sub>8</sub> × 5 <sup>3</sup> / <sub>4</sub> inches) incl. projecting parts and controls
Weight	Approx. 520 g (1 lb. 32 oz.) not incl. battery

Design and specifications subject to change without notice.

UK model	AEP, IT, G, EE model
12-hour system	24-hour system
AM 12:00 = midnight PM 12:00 = noon	0:00 = midnight 12:00 = noon

IT model: Italian model  
EE model: East European model  
G model: German model

### Location of Controls (See Illustration above.)

- |   |  |
|---|--|
| 1 Function selector (RADIO ON/OFF, ALARM RADIO/BUZZER)  | 8 Time display                               |
| 2 CLOCK set button                                      | 9 Power back-up battery compartment (bottom) |
| 3 TIME SET buttons (H/M)                                | 10 Dial scale                                |
| 4 ALARM set button                                      | 11 REPEAT ALARM/SLEEP OFF bar                |
| 5 SLEEP button  | 12 TUNING control                            |
| 6 Speaker   | 13 BAND selector FM/AM                       |
| 7 AC power cord (rear) (also function as an FM antenna) | 14 VOL (volume) control                      |

### FEATURES

- Electronic digital alarm clock and sleep timer are combined.
- Two wake-up modes available: radio or buzzer alarm.
- REPEAT ALARM bar, operable with a feather-light touch, offers two functions: snooze alarm and sleep timer turn off.
- Power back-up function to keep the clock operating during a power interruption, using an optional 6F22 battery.

#### SAFETY-RELATED COMPONENT WARNING!!

COMPONENTS IDENTIFIED BY MARK OR DOTTED LINE WITH MARK ON THE SCHEMATIC DIAGRAMS AND IN THE PARTS LIST ARE CRITICAL TO SAFE OPERATION. REPLACE THESE COMPONENTS WITH SONY PARTS WHOSE PART NUMBERS APPEAR AS SHOWN IN THIS MANUAL OR IN SUPPLEMENTS PUBLISHED BY SONY.

FM/AM DIGITAL CLOCK RADIO  
**SONY**®

# SECTION 1 GENERAL

## 1-1. MODEL IDENTIFICATION

— Model Number Label —  
Carved on lower cabinet

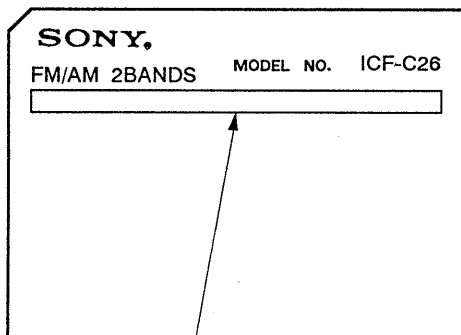

AEP, IT, G, EE model: AC: 220-230 V 50 Hz 5W  
UK model: AC: 240 V 50 Hz 5W

## 1-2. MAIN BOARD REMOVAL

- ① Turn TUNING knob fully clockwise.
- ② Release fook.
- ③ Remove main board pressing down TUNING knob.

Note: When installing main board, align shaft of VOL knob with a hole of adjustable resistor.

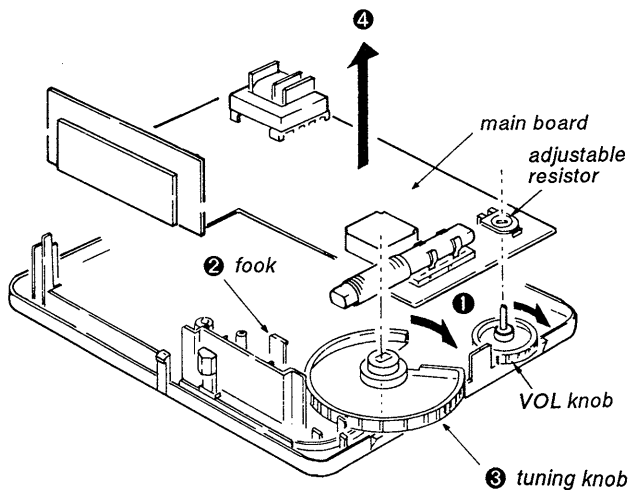

## SAFETY STANDARD UK ONLY

Dress Power Cord.

- Ⓐ Push to groove completely.
- Ⓑ Wond once around boss.
- Ⓒ Dress between boss & rib.

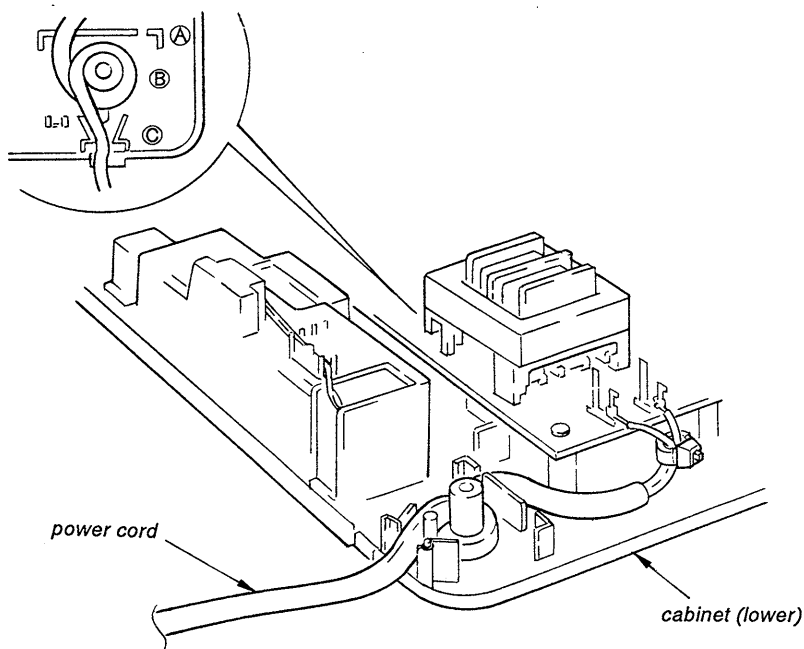

This section is extracted from instruction manual.

### 1-3. FUNCTION OF CONTROLS

**Setting the Clock** These illustrations show the display of the 12-hour system model.  
**Réglage de l'horloge** Ces illustrations montrent le modèle au système de 12 heures.  
**Puesta en hora del reloj** Estas ilustraciones corresponden a la visualización del modelo con sistema de 12 horas.  
**Instellen van de klok** Deze afbeeldingen tonen het model met 12-uurs cyclus.  
**Einstellung der Uhr** Die Abbildung zeigt die Anzeige eines Modells mit 12-Stunden-System.  
**Regolazione dell'orologio** Queste illustrazioni mostrano la visualizzazione del modello con ciclo di 12 ore.

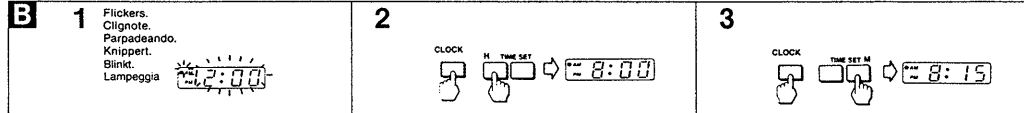

**Radio Operation** **Bediening van de radio**  
**Fonctionnement de la radio** **Radlobetrieb**  
**Radiorecepción** **Funzionamento della radio**

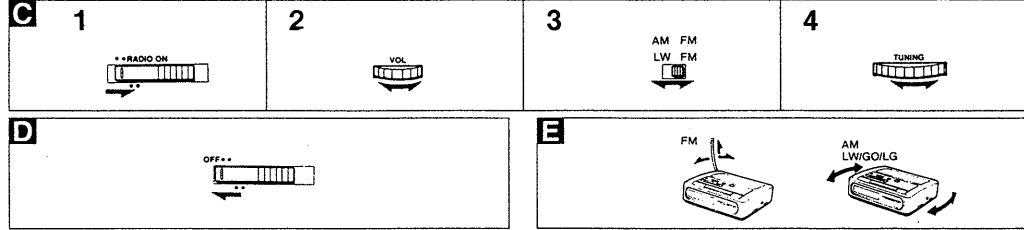

**Setting the Alarm (RADIO or BUZZER)** **Instellen van de wekker (radio of zoemer)**  
**Réglage de l'alarme (radio ou sonnerie)** **Einstellen des Alarms (Radio oder Summer)**  
**Ajuste del despertador (radio o zumbador)** **Regolazione della sveglia (radio o cicalino)**

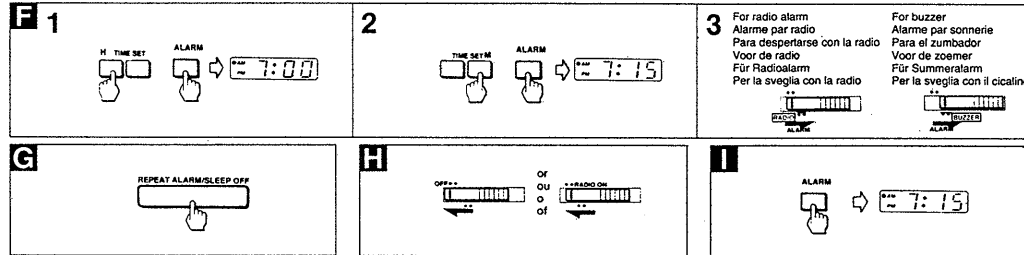

**Setting the Sleep Timer** **Instellen van de sluimerfunctie**  
**Réglage de la minuterie sommeil** **Einstellen der Abschaltautomatik**  
**Ajuste del cronodesconector** **Regolazione del timer per lo spegnimento ritardato**

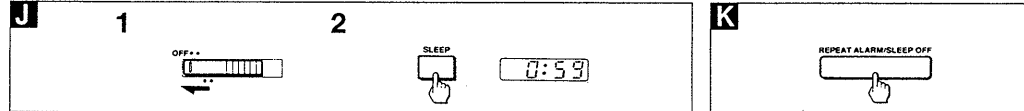

#### Setting the Clock (See illustration B.)

**Example:** To set to 8:15 am

- Plug in the unit.** The display of the 24-hour system model will show 0:00.
- Set the hour.** While pressing the CLOCK button, press the H button. Then the hour digits advance.
- Set the minute.** While pressing the CLOCK button, press the M button. Then the minute digits advance. Release the CLOCK button just at 8:15 am. The clock will begin to operate.

- Each press on the H or M button advances the displayed number by one.
- The minute digits advance to "00" after "59". The hour digits do not advance by pressing the M button.

**To adjust the time exactly to the second, release the H or M button simultaneously with the radio or telephone time signal.**

**12-hour system model**  
 AM 12:00 = Midnight  
 PM 12:00 = Noon

**24-hour system model**  
 0:00 = Midnight  
 12:00 = Noon

#### Setting the Alarm (RADIO or BUZZER) (See illustration F.)

For radio alarm, first tune in the desired station and adjust the volume.

**Example:** to set the alarm time to 7:15 am

- Set the hour.** While pressing the ALARM button, press the H button. Then the hour digits advance.
- Set the minute.** While pressing the ALARM button, press the M button. Then the minute digits advance.
- Set the function selector.** The desired alarm sound comes on at the preset time, and shuts off automatically after 119 minutes.

**If you want to doze a few more minutes (See illustration G.)**  
 The alarm sound is silenced, but automatically comes on again about nine minutes later. You can repeat this REPEAT ALARM function as many times as you like.

**To cancel the alarm mode completely (See illustration H.)**  
 To set the alarm time to the same time again, repeat the step 3 above.

**The volume of the alarm sound**  
 The radio volume can be adjusted. The buzzer volume is fixed.

**To check the preset time (See illustration I.)**

#### Radio Operation (See illustration C.)

- Turn on the radio.
- Turn the VOL (volume) control to get sound.
- Select the desired band.
- Tune in the desired station.

**To stop the radio (See illustration D.)**  
 To improve the radio reception (See illustration E.)  
 FM: Extend the AC power cord fully.  
 AM/LW: Rotate the unit horizontally.

#### Setting the Sleep Timer (See illustration J.)

- While listening to the radio, set the function selector to OFF.
- Press the SLEEP button. The radio turns on, and will turn off 59 minutes later.

**To turn off the radio before the preset time (See illustration K.)**

Every time you press the SLEEP button, the sleep timer is reset to 59 minutes.

**When you set the function selector to RADIO or BUZZER**  
 If the preset alarm time comes while the sleep timer is operating, the radio or buzzer sounds depending which you set.

## SECTION 2 ELECTRICAL ADJUSTMENTS

### FM Section

### AM Section

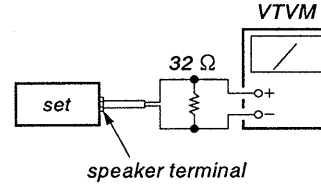
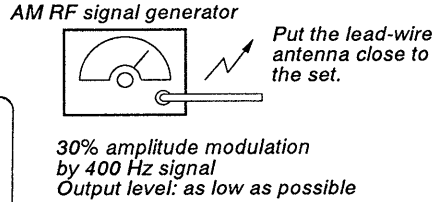
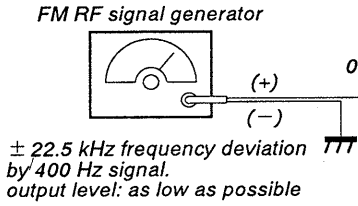

- Repeat the procedures in each adjustment several times, and the frequency coverage and tracking adjustments should be finally done by the trimmer capacitors.

#### FM FREQUENCY COVERAGE ADJUSTMENT

Adjust for a maximum reading on VTVM.

L4	87.35 (87.3) <64.0> MHz
CT2	108.05 (108.3) <109.5> MHz

#### FM TRACKING ADJUSTMENT

Adjust for a maximum reading on VTVM.

L5, L6	87.35 (87.3) <68.0> MHz
CT1	108.05 (108.3) <102.0> MHz

( ) : Italian model  
< > : East European model

#### AM IF ADJUSTMENT

Adjust for a maximum reading on VTVM.

T2	455 kHz
----	---------

#### AM FREQUENCY COVERAGE ADJUSTMENT

Adjust for a maximum reading on VTVM.

L3	520 (516.5) kHz
CT4	1,650 (1,631.5) kHz

#### AM TRACKING ADJUSTMENT

Adjust for a maximum reading on VTVM.

L7	620 kHz
CT3	1,400 kHz

[MAIN BOARD] – component side –

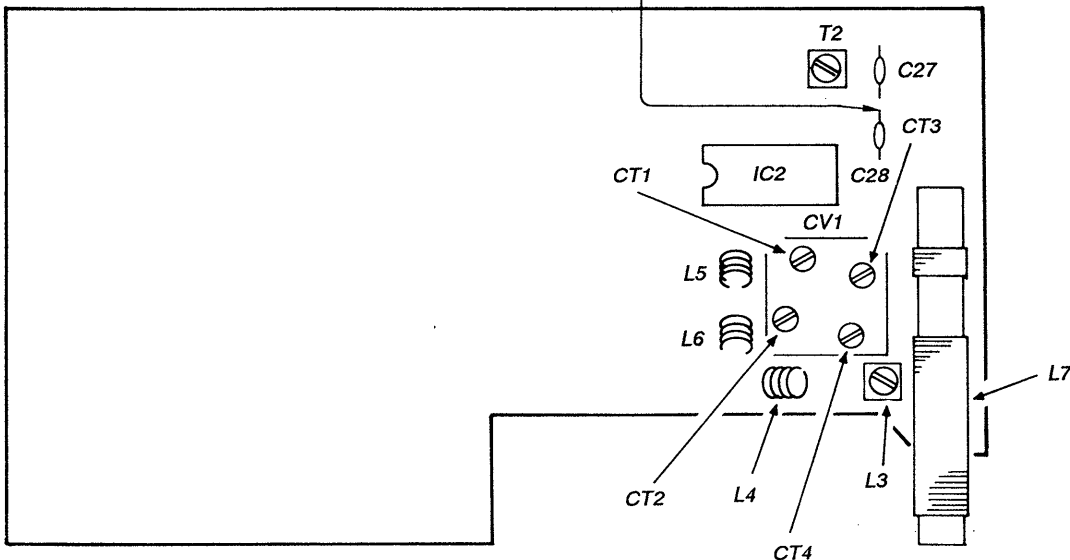

SECTION 3  
DIAGRAMS

3-1. PRINTED WIRING BOARDS

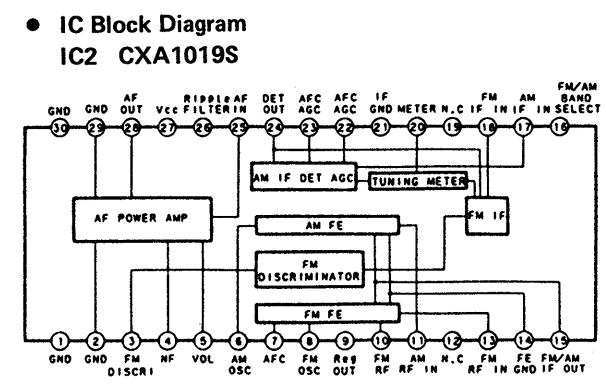
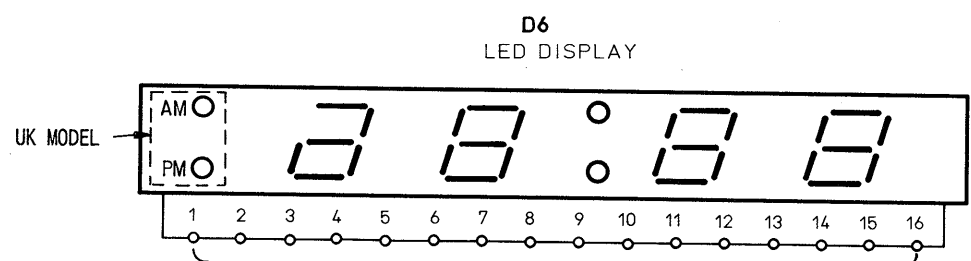
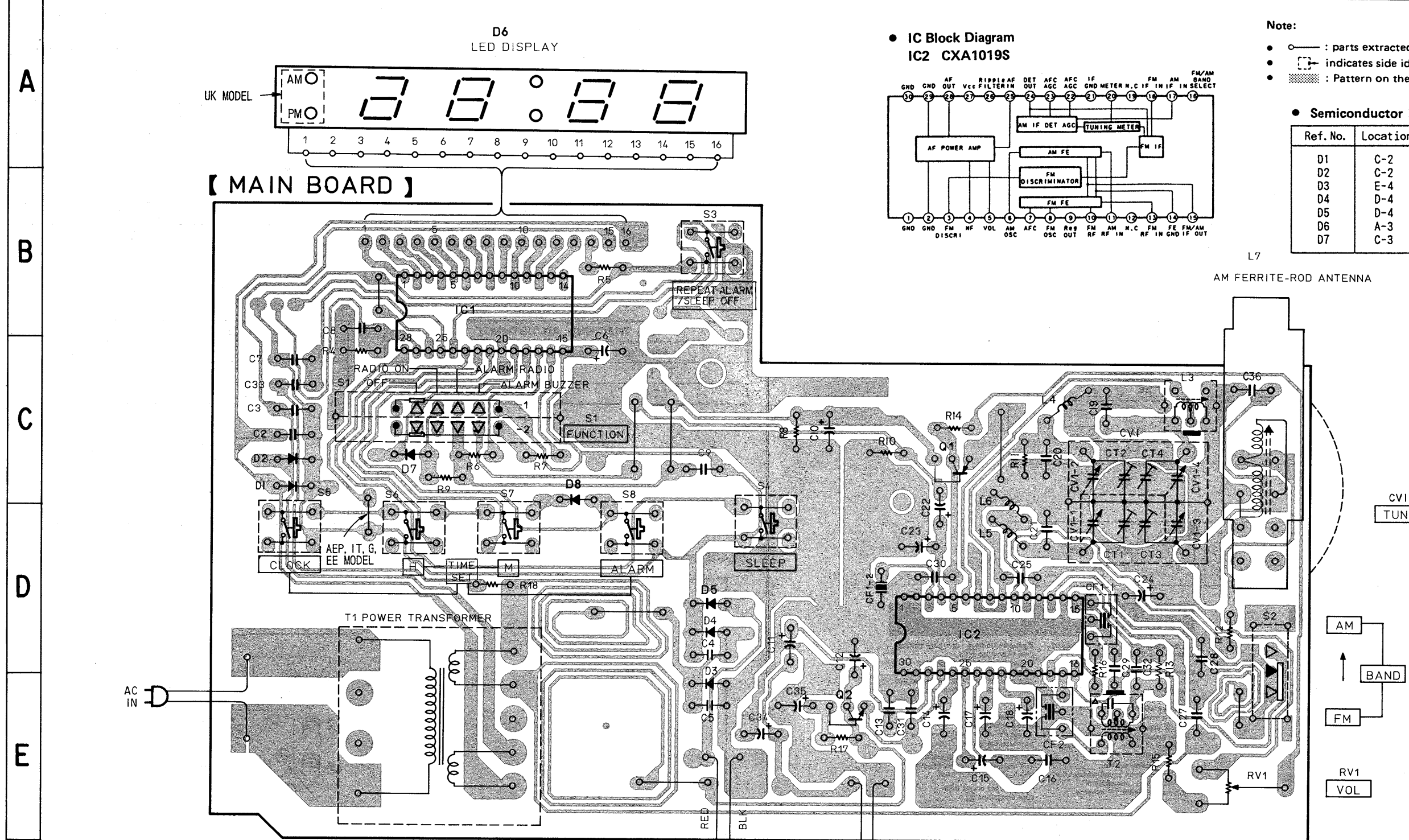
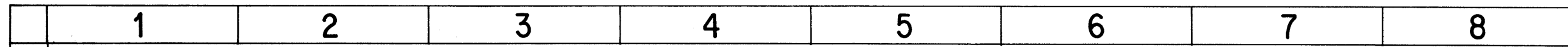

Note:

- : parts extracted from the component side.
- : indicates side identified with part number.
- ▨ : Pattern on the side which is seen.

• Semiconductor Location

Ref. No.	Location	Ref. No.	Location
D1	C-2	D8	C-4
D2	C-2	IC1	B-3
D3	E-4	IC2	D-6
D4	D-4		
D5	D-4		
D6	A-3	Q1	C-6
D7	C-3	Q2	E-5

L7  
AM FERRITE-ROD ANTENNA

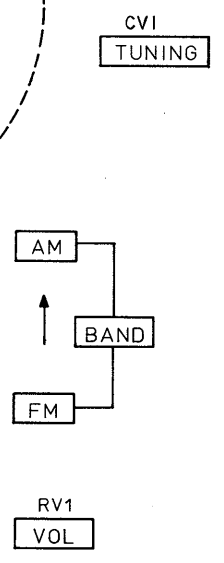

AC IN

DRY BATTERY S-006P  
( IEC DESIGNATION )  
6F22  
IPC 9V  
(POWER BACK-UP FOR CLOCK)  
(KEEP THE CORRECT TIME DURING POWER STOPAGE)

13  
23

3-2. SCHEMATIC DIAGRAM

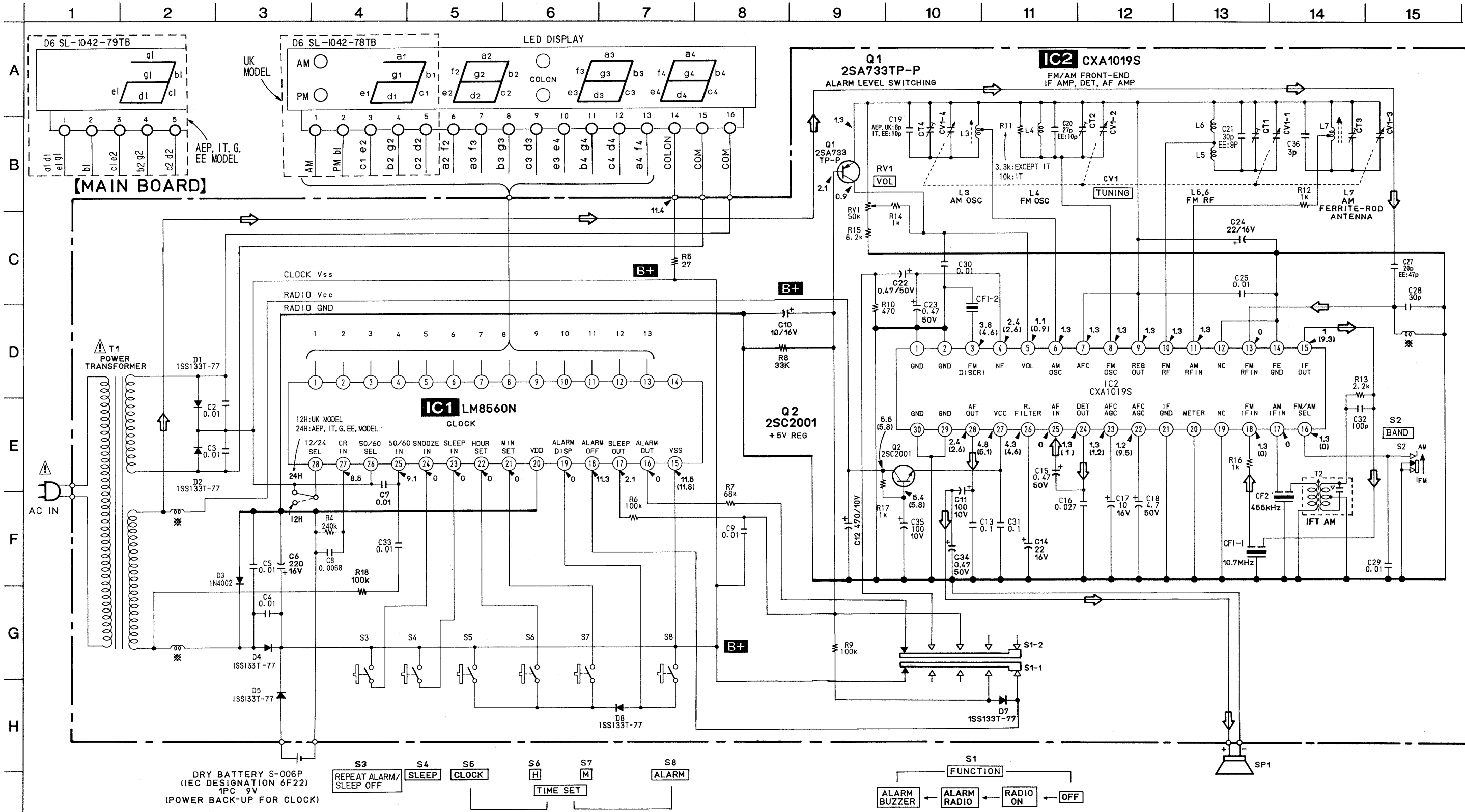

SEMICONDUCTOR LEAD LAYOUTS

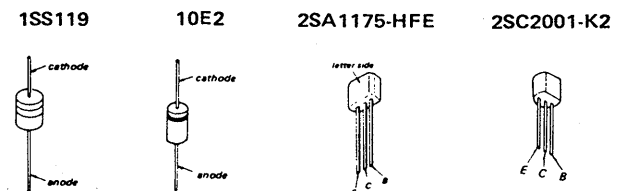

Note: The components identified by mark or dotted line with mark are critical for safety. Replace only with part number specified.

- AUS model: Australian model
- IT model: Italian model.
- \*: Printed pattern functions as a kind of coil.
- All capacitors are in  $\mu\text{F}$  unless otherwise noted. pF:  $\mu\text{F}$  50WV or less are not indicated except for electrolytics and tantalums.
- All resistors are in  $\Omega$  and  $\frac{1}{4}\text{W}$  or less unless otherwise specified.
- $\Delta$ : internal component.
- : B+ lines.
- Voltage and waveforms are dc with respect to ground

- under detuned conditions.
- no mark: FM
- ( ): AM
- Voltages are taken with a VOM. (input impedance 10 M $\Omega$ ) Voltage variations may be noted due to normal production tolerances.
- Signal path.
- $\Rightarrow$ : FM

## SECTION 4 EXPLODED VIEW

**NOTE:**

- -XX and -X mean standardized parts, so they may have some difference from the original one.

- Color Indication of Appearance Parts  
Example:  
KNOB, BALANCE (WHITE) ... (RED)

Parts Color      Cabinet's Color

- Items marked "\*" are not stocked since they are seldom required for routine service. Some delay should be anticipated when ordering these items.
- The mechanical parts with no reference number in the exploded views are not supplied.
- Hardware (# mark) list is given in the last of this parts list.

The components identified by mark  $\Delta$  or dotted line with mark  $\Delta$  are critical for safety. Replace only with part number specified.

- IT model: Italian model
- G model: German model
- EE model: East European model

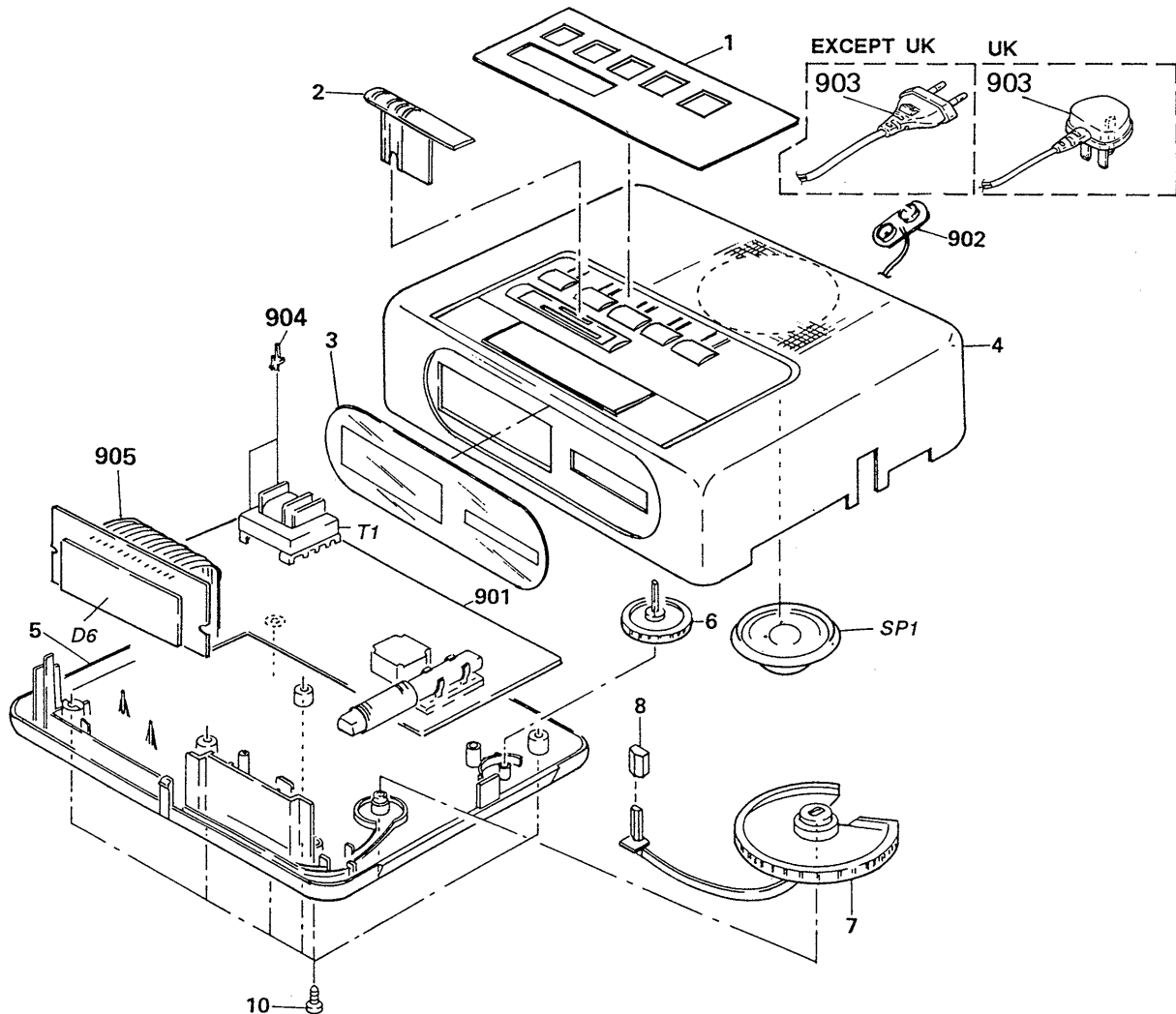

Ref. No.	Part No.	Description	Remark
1	3-377-806-01	PLATE, ORNAMENTAL (WHITE)	
1	3-377-806-11	PLATE, ORNAMENTAL (BLACK)	
2	3-902-808-01	KNOB (FUNCTION) (BLACK)	
2	3-902-808-11	KNOB (FUNCTION) (WHITE)	
3	3-377-807-21	PLATE, DIAL (AEP, G)	
3	3-377-807-31	PLATE, DIAL (IT)	
3	3-377-807-41	PLATE, DIAL (UK)	
3	3-907-002-01	PLATE, DIAL (EE)	
4	3-377-806-01	CABINET (UPPER) (BLACK)	
4	3-377-806-11	CABINET (UPPER) (WHITE)	
5	3-903-139-91	CABINET (LOWER) (BLACK)	
5	3-903-140-01	CABINET (LOWER) (WHITE)	
6	3-902-091-01	KNOB (VOL) (GRAY) (BLACK)	
6	3-902-091-11	KNOB (VOL) (LIGHT GRAY) (WHITE)	
7	3-902-474-01	KNOB (TUNING) (GRAY) (GRAY, BLACK)	
7	3-902-474-11	KNOB (TUNING) (LIGHT GRAY) (WHITE)	

Ref. No.	Part No.	Description	Remark
* 8	3-902-463-11	CAP (POINTER)	
10	7-685-648-79	SCREW +BTP 3X12 TYPE2 N-S	
* 901	A-3615-360-A	MOUNTED PCB, MAIN (IT)	
* 901	A-3615-361-A	MOUNTED PCB, MAIN (AEP, G)	
* 901	A-3661-890-A	MOUNTED PCB, MAIN (EE)	
* 901	A-3661-898-A	MOUNTED PCB, MAIN (UK)	
902	1-535-804-21	SNAP, BATTERY	
$\Delta$ 903	1-555-795-00	CORD, POWER (AEP, IT, G, EE)	
$\Delta$ 903	1-696-572-21	CORD, POWER (UK)	
904	1-535-476-11	TERMINAL (AEP, IT, G)	
904	1-535-771-21	TERMINAL (UK, EE)	
* 905	1-575-159-11	CORD, CONNECTION	
D6	1-808-342-11	DIODE SL-1042-78T (UK)	
D6	1-808-544-11	DIODE SL-1042-79T (AEP, IT, G, EE)	
SP1	1-503-082-00	SPEAKER	
$\Delta$ T1	1-499-940-11	TRANSFORMER, POWER	

# SECTION 5

## ELECTRICAL PARTS LIST

**NOTE:**

- Due to standardization, replacements in the parts list may be different from the parts specified in the diagrams or the components used on the set.
- -XX and -X mean standardized parts, so they may have some difference from the original one.
- RESISTORS  
All resistors are in ohms.  
METAL: Metal-film resistor.  
METAL OXIDE: Metal oxide-film resistor.  
F: nonflammable

- Items marked "\*" are not stocked since they are seldom required for routine service. Some delay should be anticipated when ordering these items.
- SEMICONDUCTORS  
In each case, u:  $\mu$ , for example:  
uA ..:  $\mu$ A.. uPA..:  $\mu$ PA..  
uPB..:  $\mu$ PB.. uPC..:  $\mu$ PC.. uPD..:  $\mu$ PD..
- CAPACITORS  
uF:  $\mu$ F
- COILS  
uH:  $\mu$ H

The components identified by mark  $\Delta$  or dotted line with mark  $\Delta$  are critical for safety. Replace only with part number specified.

- IT model: Italian model
- G model: German model
- EE model: East European model

Ref. No.	Part No.	Description	Remark
* 901	A-3615-360-A	MOUNTED PCB, MAIN (IT)	
* 901	A-3615-361-A	MOUNTED PCB, MAIN (AEP, G)	
* 901	A-3661-890-A	MOUNTED PCB, MAIN (EE)	
* 901	A-3661-898-A	MOUNTED PCB, MAIN (UK)	
$\Delta$ 903	1-555-795-00	CORD, POWER (AEP, IT, G, EE)	
$\Delta$ 903	1-696-572-21	CORD, POWER (UK)	
904	1-535-476-11	TERMINAL (AEP, IT, G)	
904	1-535-771-21	TERMINAL (UK, EE)	
* 905	1-575-159-11	CORD, CONNECTION	
C2	1-101-004-00	CERAMIC 0.01MF	50V
C3	1-101-004-00	CERAMIC 0.01MF	50V
C4	1-101-004-00	CERAMIC 0.01MF	50V
C5	1-101-004-00	CERAMIC 0.01MF	50V
C6	1-124-120-11	ELECT 220MF	20% 16V
C7	1-101-004-00	CERAMIC 0.01MF	50V
C8	1-161-049-00	MYLAR 0.0068MF	5% 50V
C9	1-161-379-00	CERAMIC 0.01MF	30% 16V
C10	1-123-356-00	ELECT 10MF	20% 16V
C11	1-126-101-11	ELECT 100MF	20% 10V
C12	1-124-472-11	ELECT 470MF	20% 10V
C13	1-162-851-11	CERAMIC 0.1MF	20% 16V
C14	1-123-330-00	ELECT 22MF	20% 16V
C15	1-123-379-00	ELECT 0.47MF	20% 50V
C16	1-161-056-00	CERAMIC 0.027MF	10% 25V
C17	1-123-356-00	ELECT 10MF	20% 16V
C18	1-123-369-00	ELECT 4.7MF	20% 50V
C19	1-102-945-00	CERAMIC 8PF	0.5PF 50V (AEP, UK)
C19	1-102-947-00	CERAMIC 10PF	0.5PF 50V (IT)
C19	1-102-997-00	CERAMIC 10PF	(EE)
C20	1-102-858-00	CERAMIC 10PF	(EE)
C20	1-102-961-00	CERAMIC 27PF	5% 50V (EXCEPT EE)
C21	1-102-946-00	CERAMIC 9PF	(EE)
C21	1-102-962-01	CERAMIC 30PF	5% 50V (EXCEPT EE)
C22	1-123-379-00	ELECT 0.47MF	20% 50V
C23	1-123-379-00	ELECT 0.47MF	20% 50V
C24	1-123-330-00	ELECT 22MF	20% 16V
C25	1-101-004-00	CERAMIC 0.01MF	50V
C27	1-101-880-00	CERAMIC 47PF	5% 50V (EE)

Ref. No.	Part No.	Description	Remark
C27	1-102-958-00	CERAMIC 20PF	5% 50V (EXCEPT EE)
C28	1-102-962-00	CERAMIC 30PF	5% 50V
C29	1-101-004-00	CERAMIC 0.01MF	50V
C30	1-101-004-00	CERAMIC 0.01MF	50V
C31	1-162-851-11	CERAMIC 0.1MF	20% 16V
C32	1-102-973-00	CERAMIC 100PF	5% 50V
C33	1-101-004-00	CERAMIC 0.01MF	50V
C34	1-123-379-00	ELECT 0.47MF	20% 50V
C35	1-126-101-11	ELECT 100MF	20% 10V
C36	1-102-936-00	CERAMIC 3PF	0.25PF 50V
CF1	1-567-166-00	FILTER, CERAMIC	
CF2	1-577-072-11	FILTER, CERAMIC	
CT1-4	1-151-614-11	CAP, VARIABLE (EXCEPT EE)	
CV1	1-141-487-11	CAP, VARIABLE (EE)	
D1	8-719-911-19	DIODE 1SS119	
D2	8-719-911-19	DIODE 1SS119	
D3	8-719-200-02	DIODE 10E2	
D4	8-719-911-19	DIODE 1SS119	
D5	8-719-911-19	DIODE 1SS119	
D6	1-808-342-11	DIODE SL-1042-78T (UK)	
D6	1-808-344-11	DIODE SL-1042-79T (AEP, IT, G, EE)	
D7	8-719-911-19	DIODE 1SS119	
D8	8-719-911-19	DIODE 1SS119	
IC1	8-759-821-46	IC LM8560N	
IC2	8-752-035-29	IC CXA1019S	
L3	1-406-150-11	COIL, MW OSC	
L4	1-428-241-11	COIL, AIR-CORE (EE)	
L4	1-459-815-11	COIL, (WITH CORE), FM OSC (EXCEPT EE)	
* L5	1-422-291-11	COIL, AIR-CORE (FM RF) (EXCEPT EE)	
L5	1-428-164-11	COIL, AIR-CORE (EE)	
* L6	1-422-291-11	COIL, AIR-CORE (RM RF) (EXCEPT EE)	
L6	1-428-163-11	COIL, AIR-CORE (EE)	
L7	1-402-405-11	ANTENNA, FERRITE-ROD (MW)	
Q1	8-729-119-76	TRANSISTOR 2SA1175-HEF	
Q2	8-729-100-13	TRANSISTOR 2SC2001-K2	
R4	1-247-888-11	CARBON 270K	5% 1/4W
R5	1-249-398-11	CARBON 27	5% 1/4W



Ref. No.	Part No.	Description			Remark
R6	1-249-441-11	CARBON	100K	5%	1/4W
R7	1-249-439-11	CARBON	68K	5%	1/4W
R8	1-249-435-11	CARBON	33K	5%	1/4W
R9	1-249-441-11	CARBON	100K	5%	1/4W
R10	1-249-413-11	CARBON	470	5%	1/4W
R11	1-249-423-11	CARBON	3.3K	5%	1/4W (EXCEPT IT)
R11	1-249-429-11	CARBON	10K	5%	1/4W (IT)
R12	1-249-417-11	CARBON	1K	5%	1/4W
R13	1-249-421-11	CARBON	2.2K	5%	1/4W
R14	1-249-417-11	CARBON	1K	5%	1/4W
R15	1-249-428-11	CARBON	8.2K	5%	1/4W
R16	1-249-417-11	CARBON	1K	5%	1/4W
R17	1-249-417-11	CARBON	1K	5%	1/4W
R18	1-249-441-11	CARBON	100K	5%	1/4W
RV1	1-228-790-00	RES, VAR, CARBON 50K (VOL)			
S1	1-572-023-11	SWITCH, SLIDE (FUNCTION)			
S2	1-552-370-31	SWITCH, SLIDE (BAND)			
S3	1-553-856-00	SWITCH, KEY BOARD (REPEAT ALARM/SLEEP OFF)			
S4	1-553-856-00	SWITCH, KEY BOARD (SLEEP)			
S5	1-553-856-00	SWITCH, KEY BOARD (CLOCK)			
S6	1-553-856-00	SWITCH, KEY BOARD (TIME SET-H)			
S7	1-553-856-00	SWITCH, KEY BOARD (TIME SET-M)			
S8	1-553-856-00	SWITCH, KEY BOARD (ALARM)			
SP1	1-503-082-00	SPEAKER			
△T1	1-499-940-11	TRANSFORMER, POWER			
T2	1-404-790-11	TRANSFORMER, IF (AM)			

ACCESSORY & PACKING MATERIAL  
\*\*\*\*\*

- 3-754-706-11 MANUAL, INSTRUCTION (ENGLISH, FRENCH, SPANISH, DUTCH, GERMAN, ITALIAN) (AEP)
- 3-754-706-41 MANUAL, INSTRUCTION (ENGLISH, FRENCH, GERMAN, SWEDISH, ITALIAN, PORTUGUESE) (AEP, UK, IT, G)
- 3-754-706-61 MANUAL, INSTRUCTION (ENGLISH, POLISH, HUNGARIAN, CZECK, RUSSIAN) (EE)

- \* 3-378-613-01 INDIVIDUAL CARTON (EXCEPT UK)
- \* 3-908-058-01 INDIVIDUAL CARTON (UK)

The components identified by mark △ or dotted line with mark △ are critical for safety. Replace only with part number specified.